



Palettenregal
Palettier
Palletstelling
Pallet rack

- Aufbauanleitung (D)
- Notice de Montage (F)
- Handling voor montage (NL)
- Assembly instruction (GB)

Inhaltsverzeichnis

 Table des matières

 Inhoudsopgave

 Table of contents

RegalbauteileSeite 5

Éléments du rayonnage	Page 5
Stellingcomponenten	Pagina 5
Shelf components	Page 5

Montage Rahmen.....Seite 6-7

Montage du cadre	Page 6-7
Montage frames	Pagina 6-7
Frame assembly	Page 6-7

Montage Auflageträger.....Seite 8-9

Montage des longerons	Page 8-9
Montage steunbalken	Pagina 8-9
Support beam assembly	Page 8-9

Verankerung.....Seite 10

Ancrage au sol	Page 10
Verankerung	Pagina 10
Anchoring	Page 10

KennzeichnungSeite 11

Marquage	Page 11
Markering	Pagina 11
Labelling	Page 11

Wichtige Sicherheitshinweise Seite 22-25

Consignes de sécurité importantes	Page 22-25
Belangrijke veiligheidsaanwijzingen	Pagina 22-25
Important safety information	Page 22-25

BedienhinweiseSeite 26-27

Consignes d'utilisation	Page 26-27
Gebbruiksaanwijzing	Pagina 26-27
Operating instructions	Page 26-27

BelastungsangabenSeite 28-35

Indications de charge	Page 28-35
Laadgegevens	Pagina 28-35
Load data	Page 28-35

Toleranzen.....Seite 36

Tolérances	Page 36
Toleranties	Pagina 36
Tolerances	Page 36

ZubehörSeite 12-13

Accessoires	Page 12-13
Accessoires	Pagina 12-13
Accessories	Page 12-13

Distanzstück.....Seite 14

Entretoises	Page 14
Afstandshouder	Pagina 14
Spacer	Page 14

Durchschubsicherung.....Seite 15

Blocage anti-traversée	Page 15
Doorschuifbeveiliging	Pagina 15
Push-through protection	Page 15

Anfahrerschutz.....Seite 16

Protection anti-collision	Page 16
Aanrijbeschermer	Pagina 16
Crash protection	Page 16

Giterrückwand.....Seite 17

Panneau arrière grillagé	Page 17
Roosterachterwand	Pagina 17
Grid rear panel	Page 17

Tiefensteg.....Seite 18

Traverses	Page 18
Verlaagde steunbalk	Pagina 18
Deep web	Page 18

Gitterboxauflage.....Seite 19

Support de caisse-palette	Page 19
Roosterboxsteun	Pagina 19
Grid box support	Page 19

Spanplatte mit Z-Halter.....Seite 20

Panneau de particules avec support Z	Page 20
Spaanplaat met Z-houder	Pagina 20
Chipboard with Z-holder	Page 20

Paneelboden.....Seite 20

Plancher	Page 20
Paneelvloer	Pagina 20
Panel floor	Page 20

Gitterrost.....Seite 21

Grille	Page 21
Tralierooster	Pagina 21
Grating	Page 21

Drahtgitterboden.....Seite 21

Sol grillagé	Page 21
Raadgaas vloer	Pagina 21
Wire mesh floor	Page 21

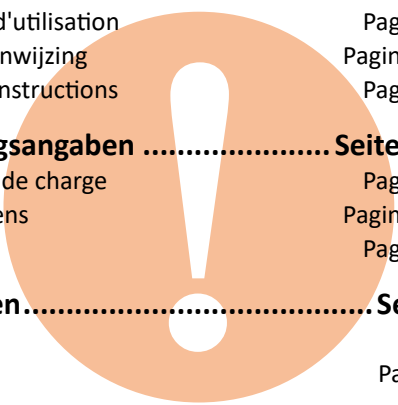



Sicherheitsvorschriften

Schutzmaßnahmen beim Aufbau beachten!

Les règles de sécurité

Respectez les mesures de protection lors du montage !

Veiligheidsvoorschriften

Neem bij de montage de beschermende maatregelen in acht!

Safety instructions

Observe protective measures during assembly!



Sicherheitshandschuhe
Gants de sécurité
Veiligheidshandschoenen
Safety Gloves



Gehörschutz
Protection auditive
Oor bescherming
Ear protection



Schutzbrille
Lunettes de sécurité
Veiligheidsbril
Safety glasses



Sicherheitshelm
Casque de sécurité
Veiligheidshelm
Safety helmet



Sicherheitsschuhe
Chaussures de sécurité
Veiligheidsschoenen
Safety shoes





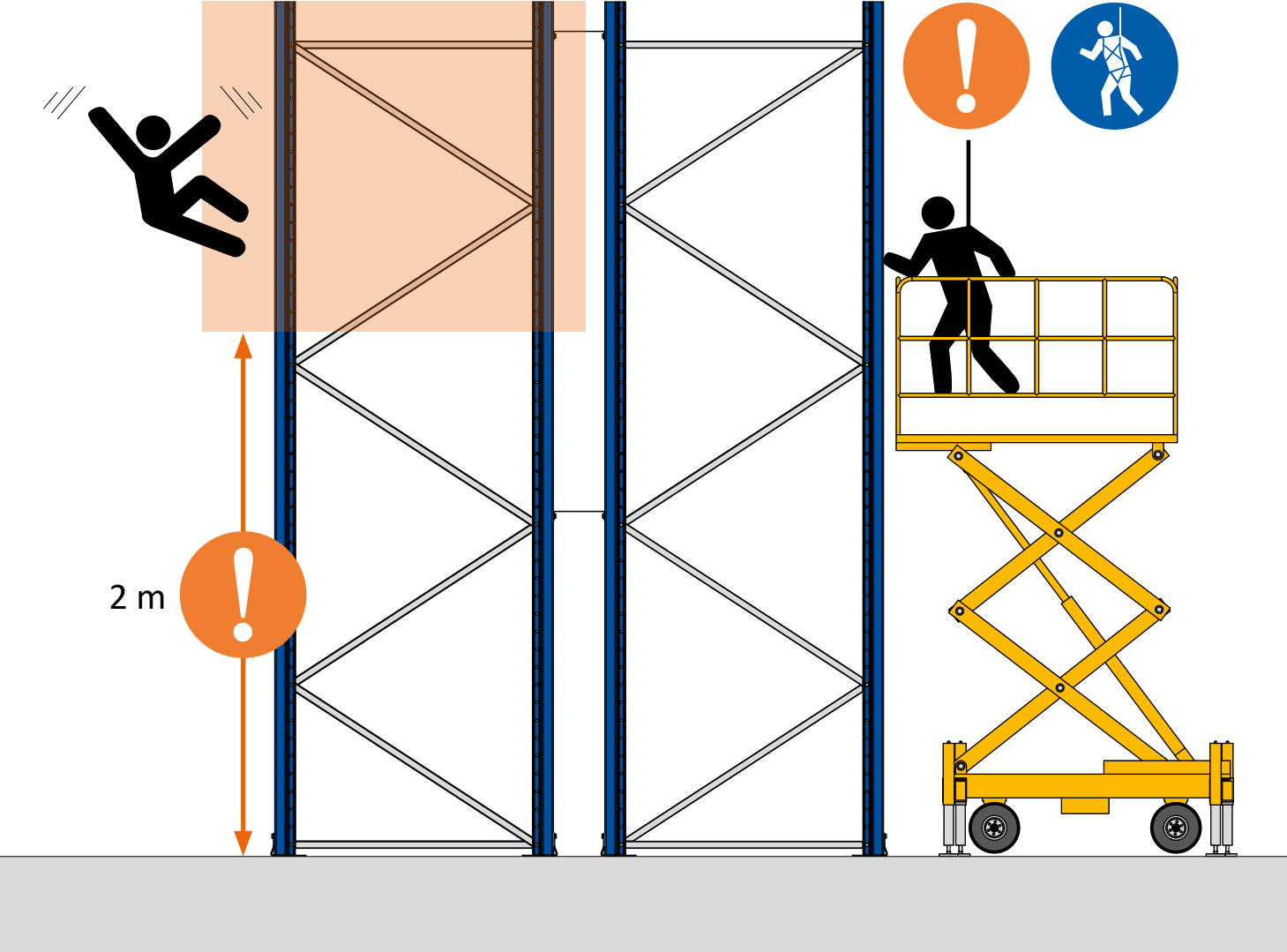

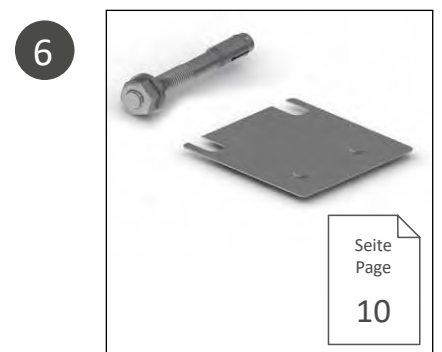
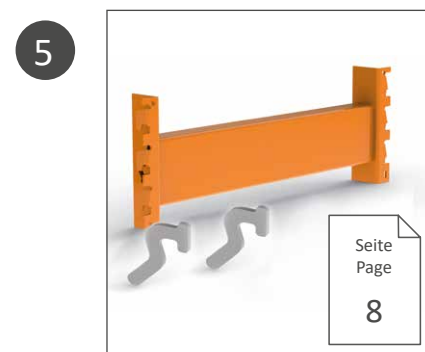
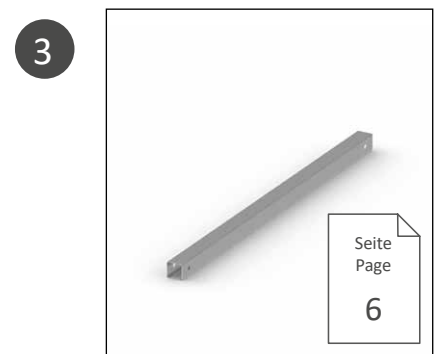
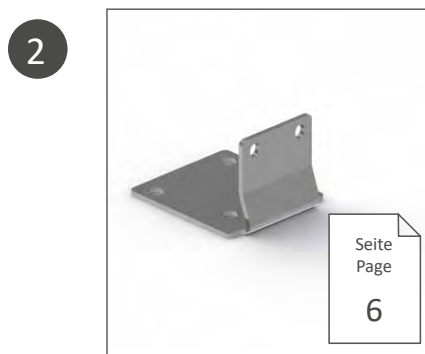
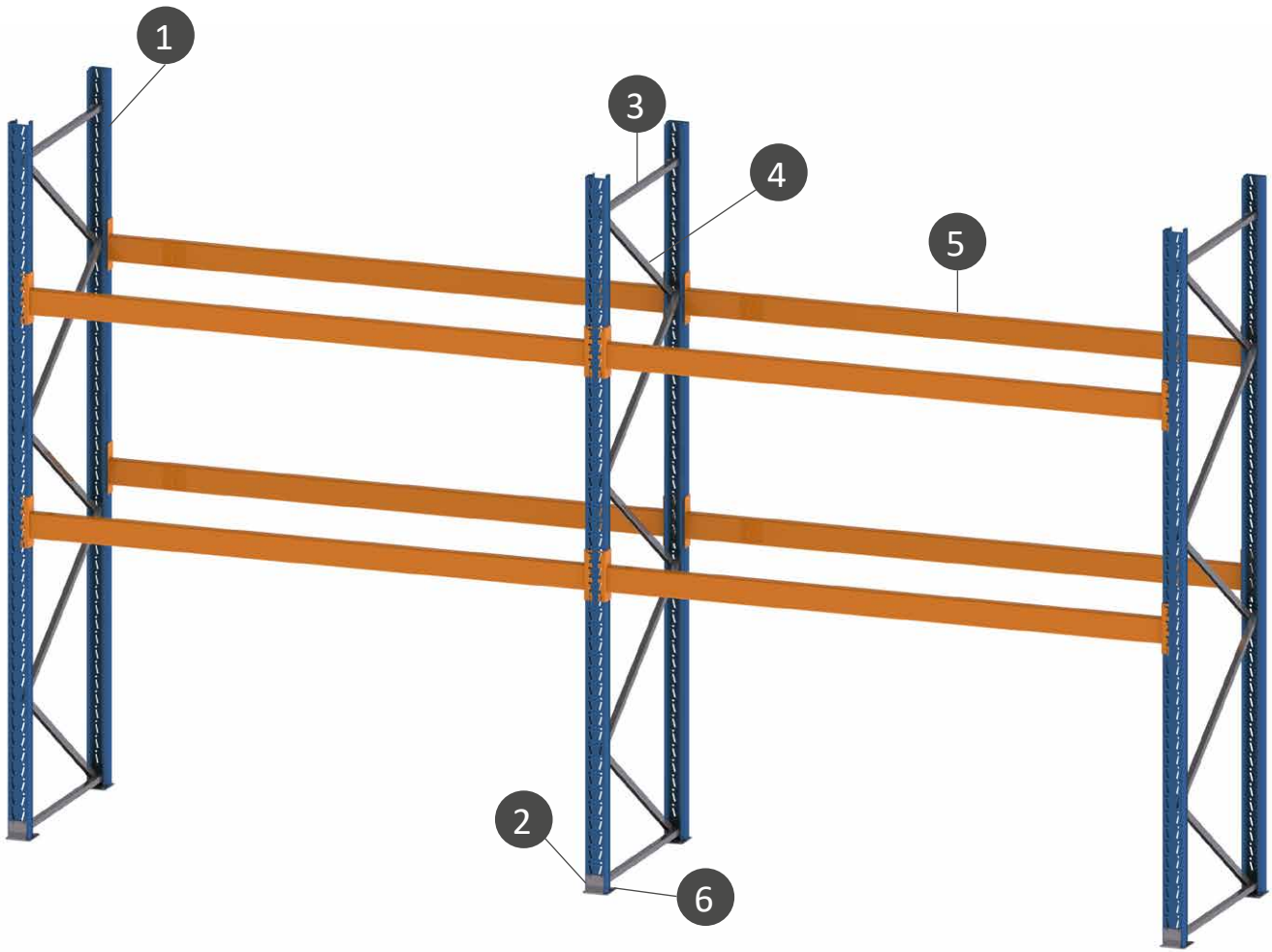
Schutzkleidung
Vêtements de travail protecteurs
Veilige werkkleding
Protective work clothing

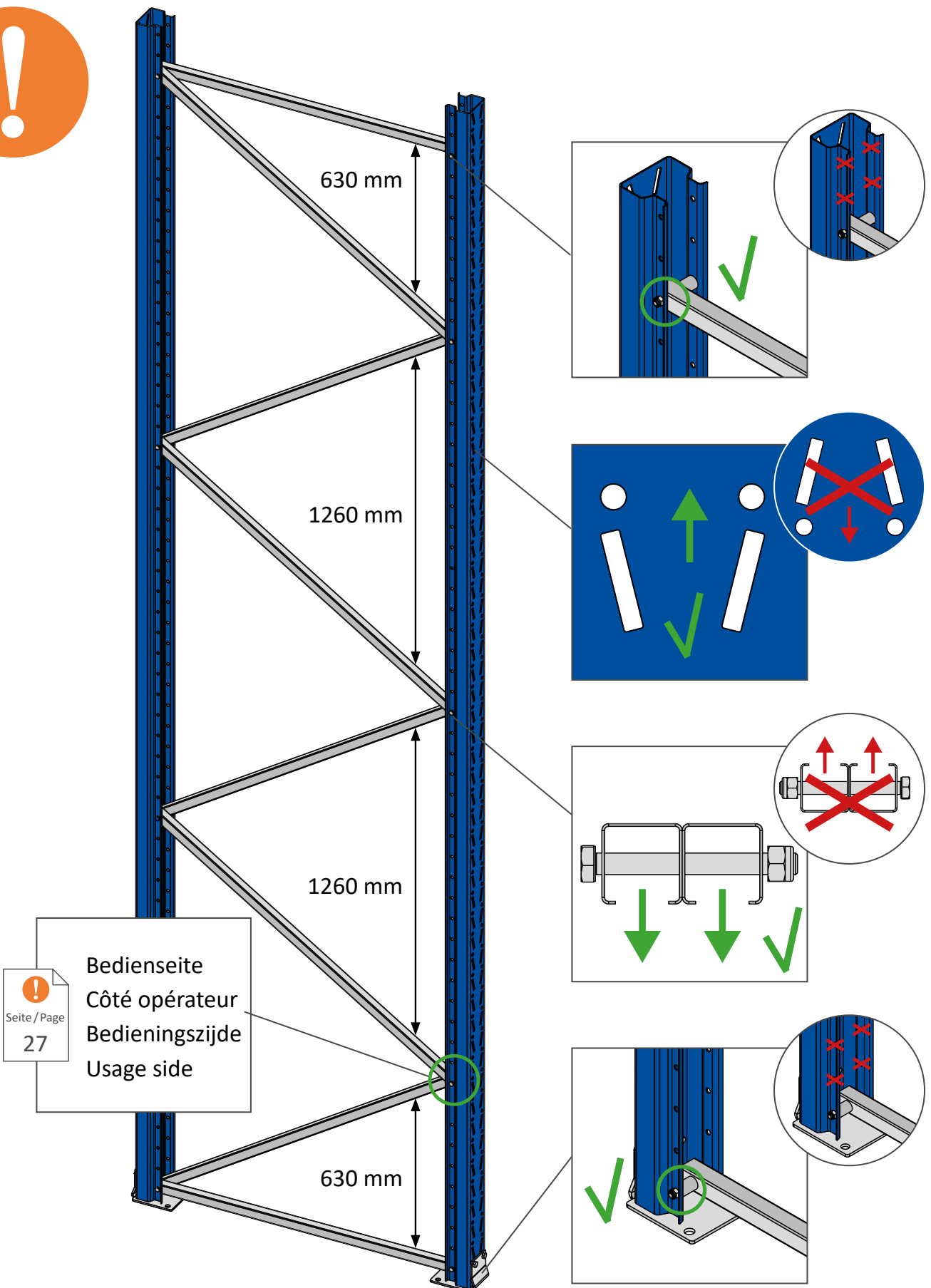

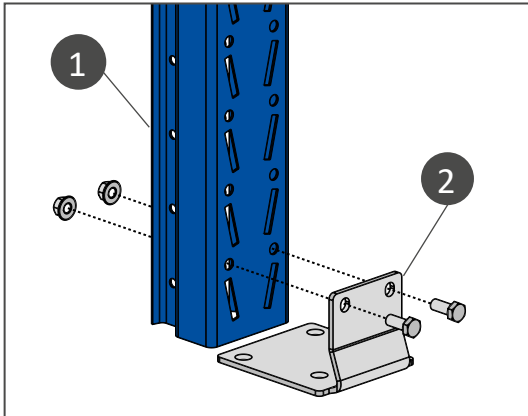



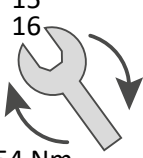



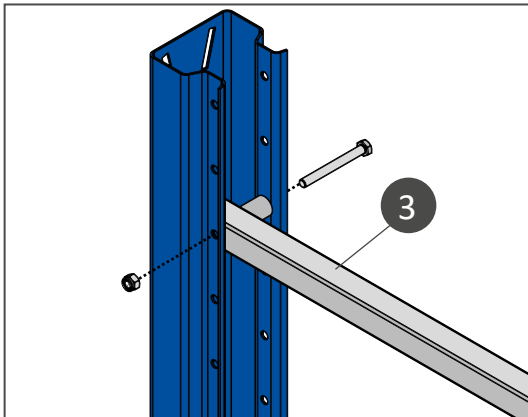



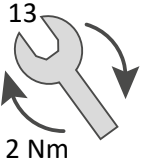

	M10 x 25 mm	 15 16 54 Nm
	M10	

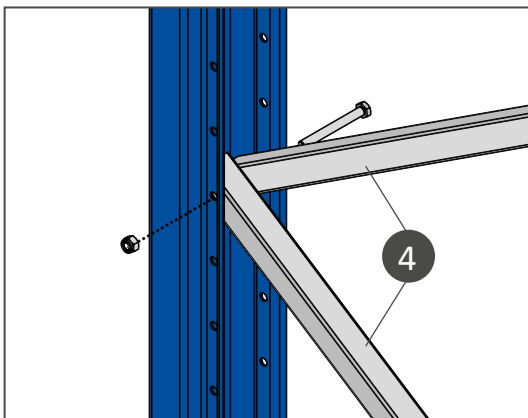

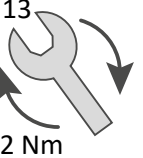

	M8 x 75 mm	 13 ≈ 2 Nm
	M8	
	∅20 mm x 30 mm	

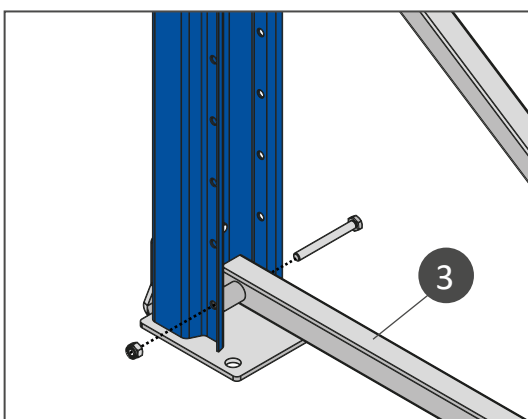

	M8 x 75 mm	 13 ≈ 2 Nm
	M8	

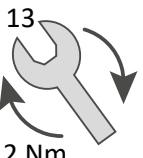

	M8 x 75 mm	 13 ≈ 2 Nm
	M8	
	∅20 mm x 30 mm	

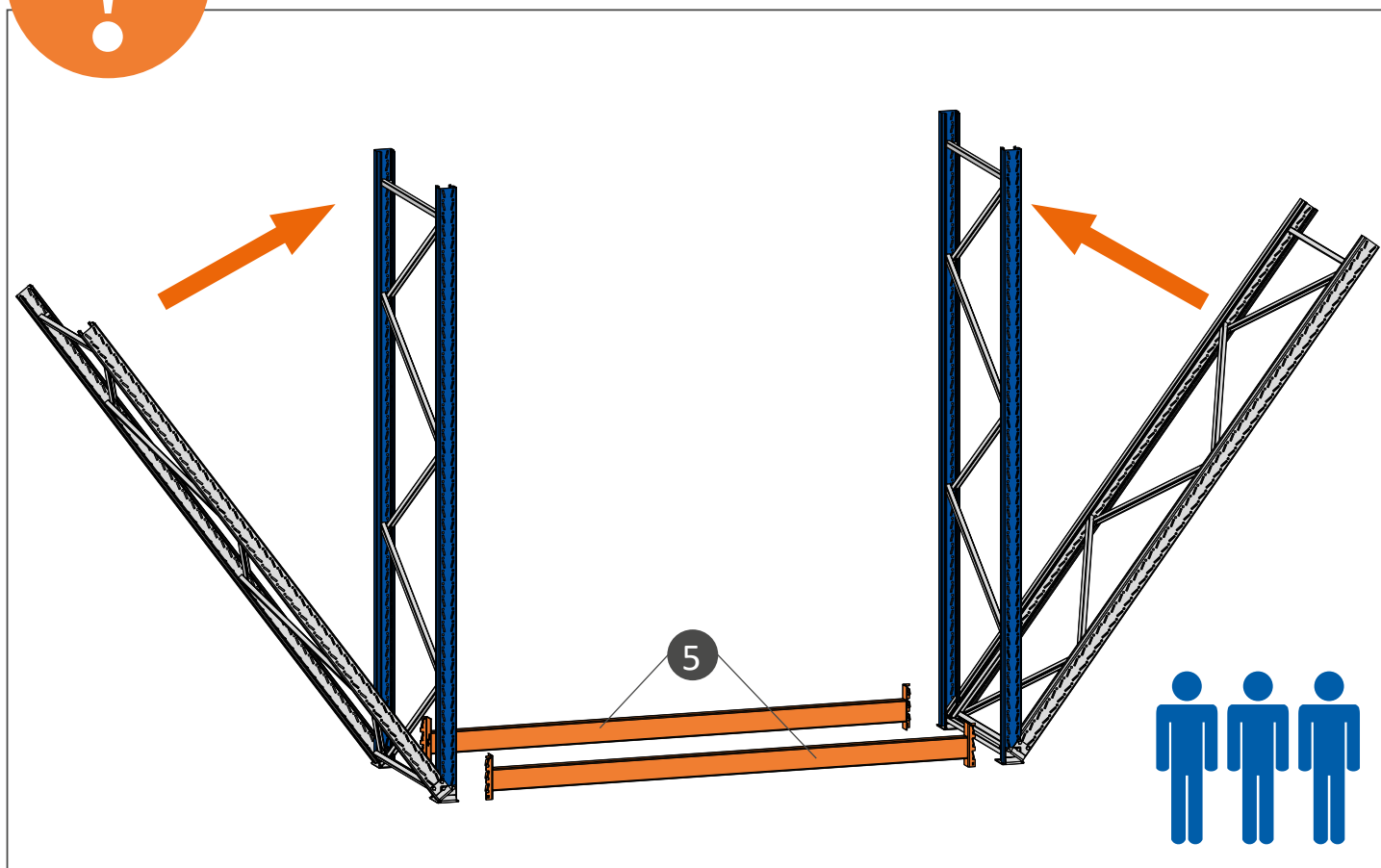
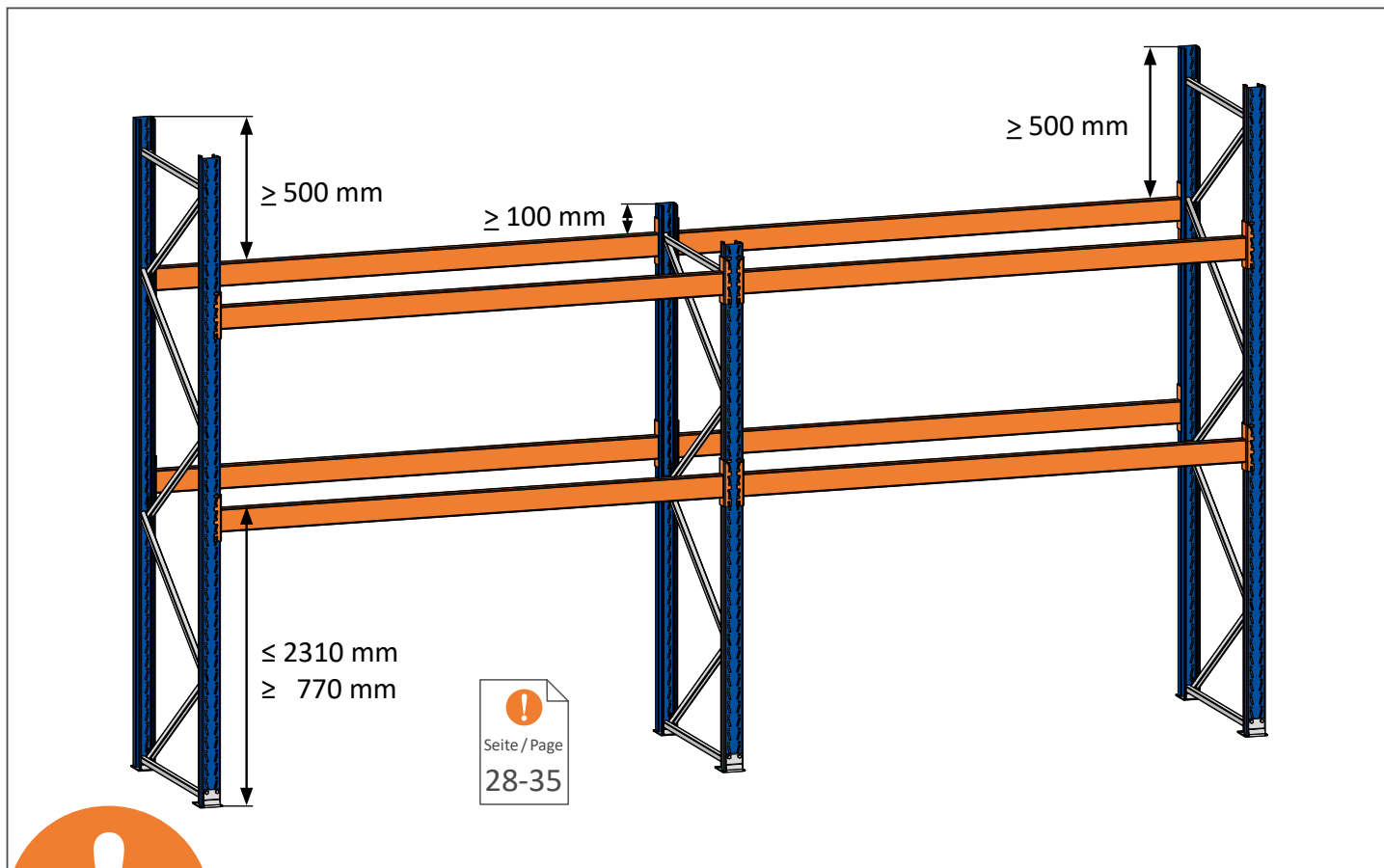

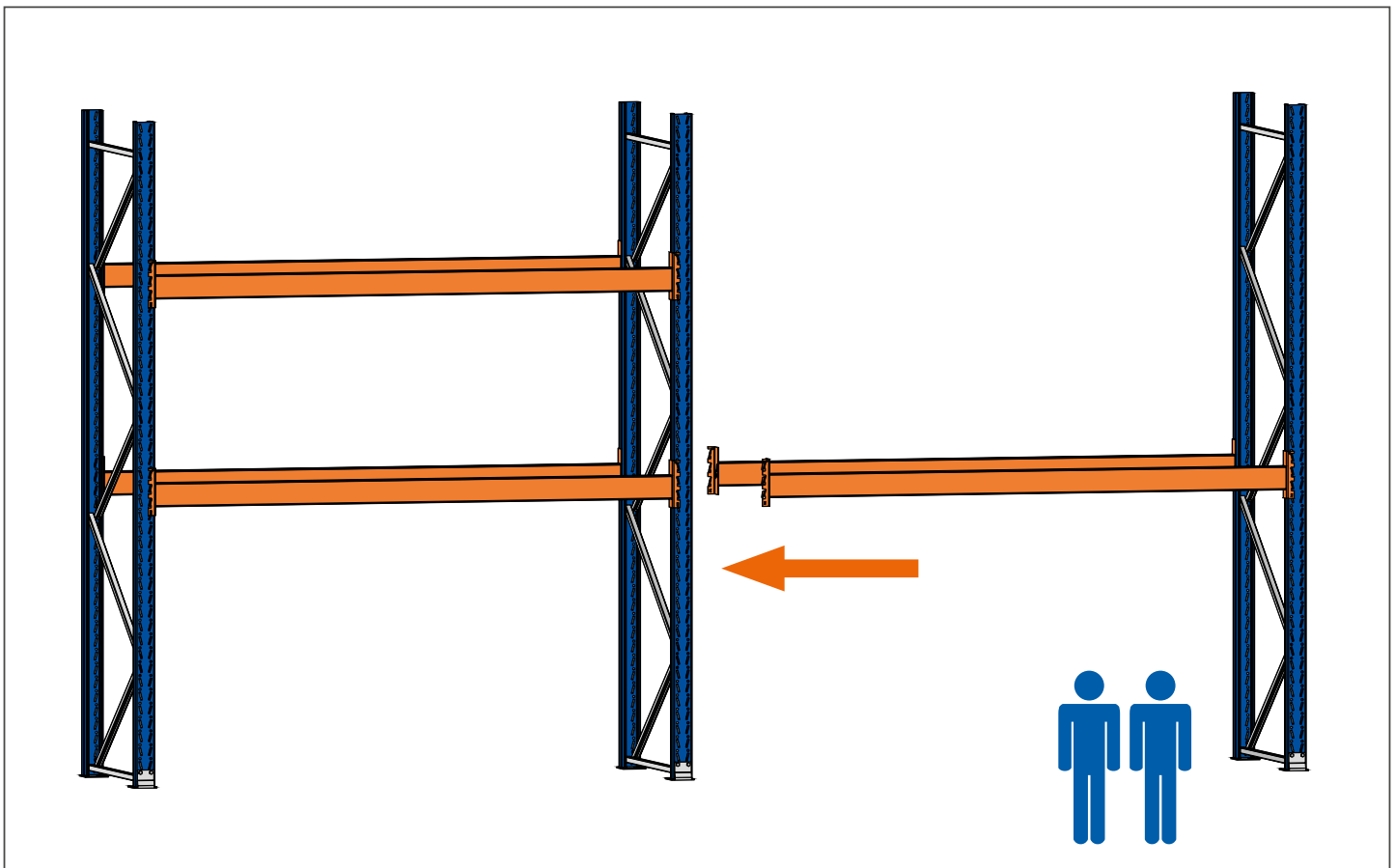
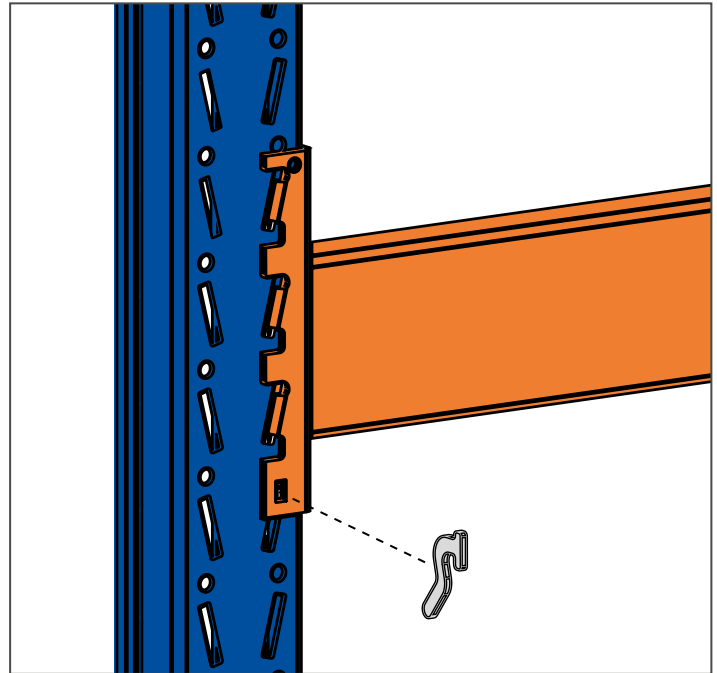
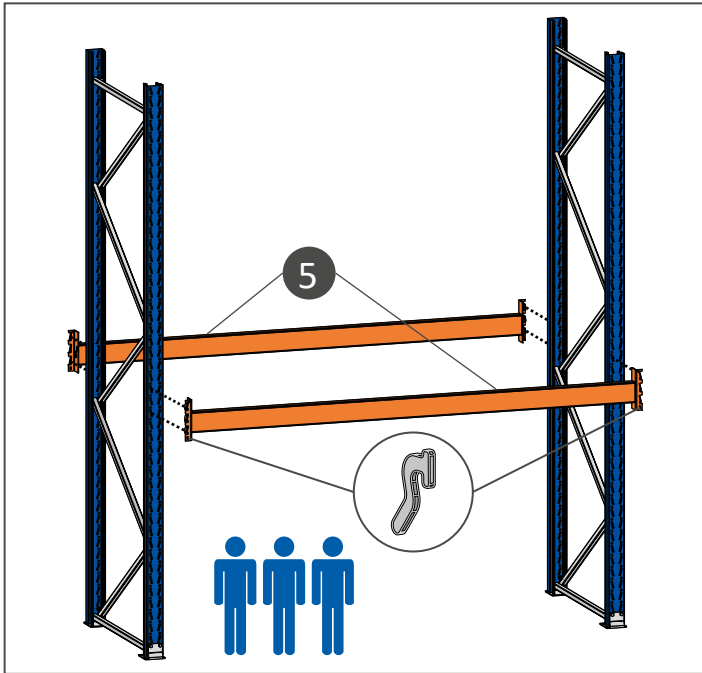

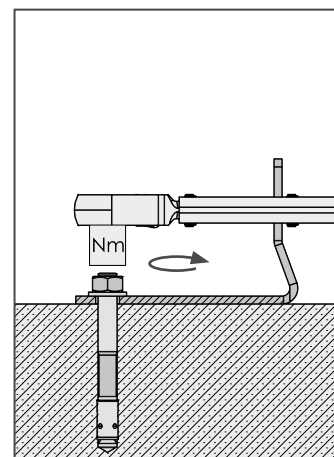
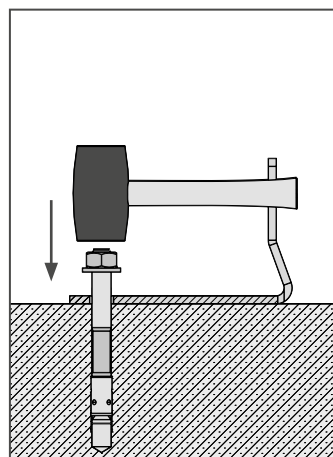
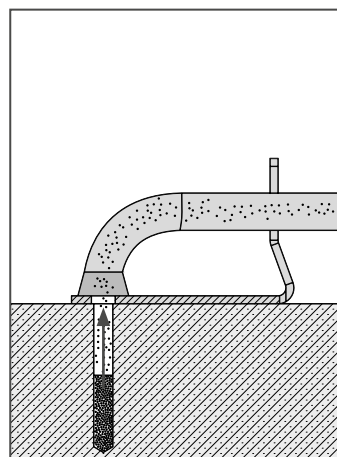
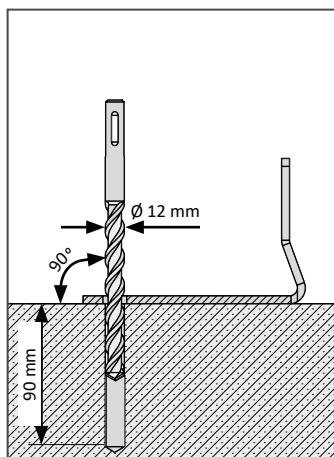
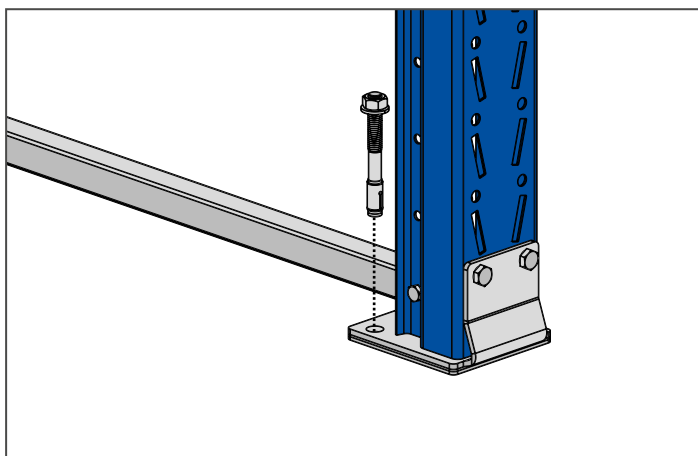
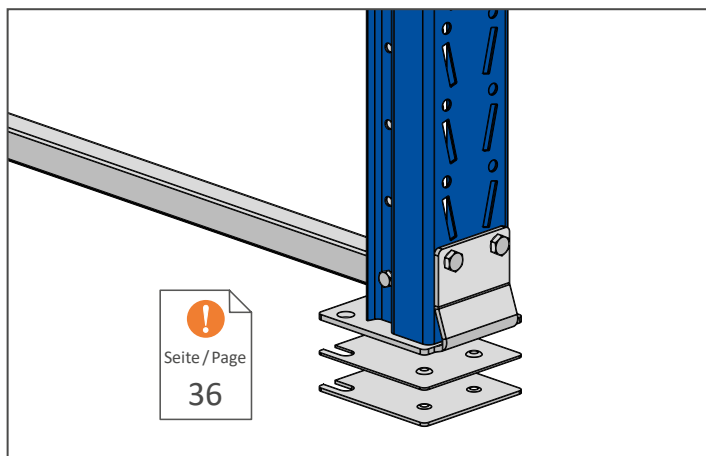
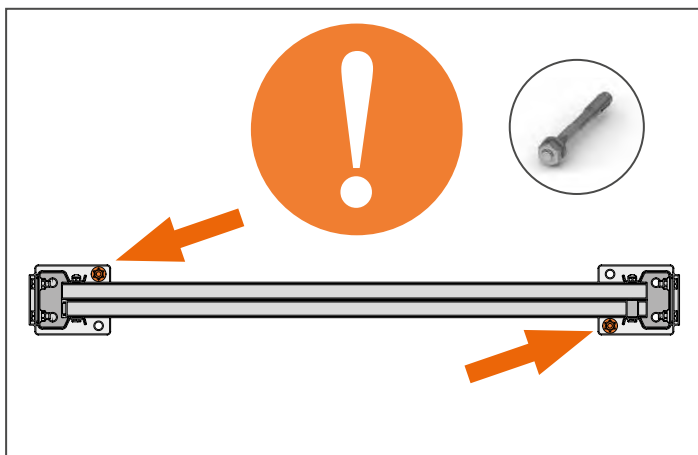
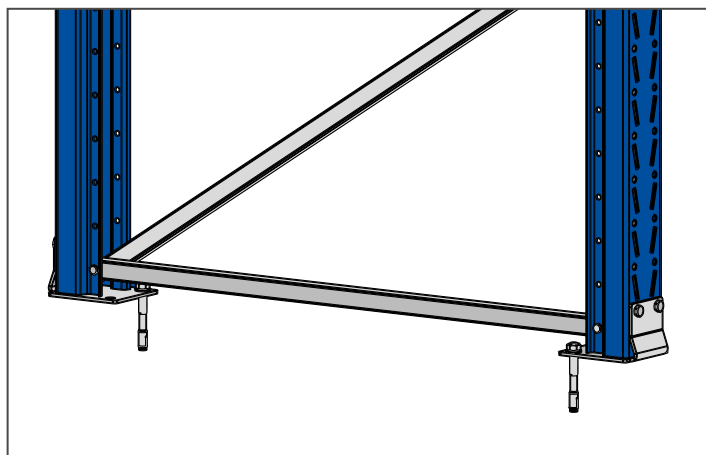
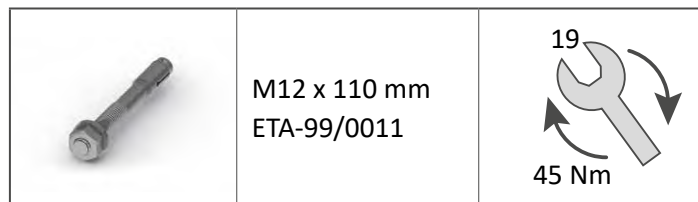

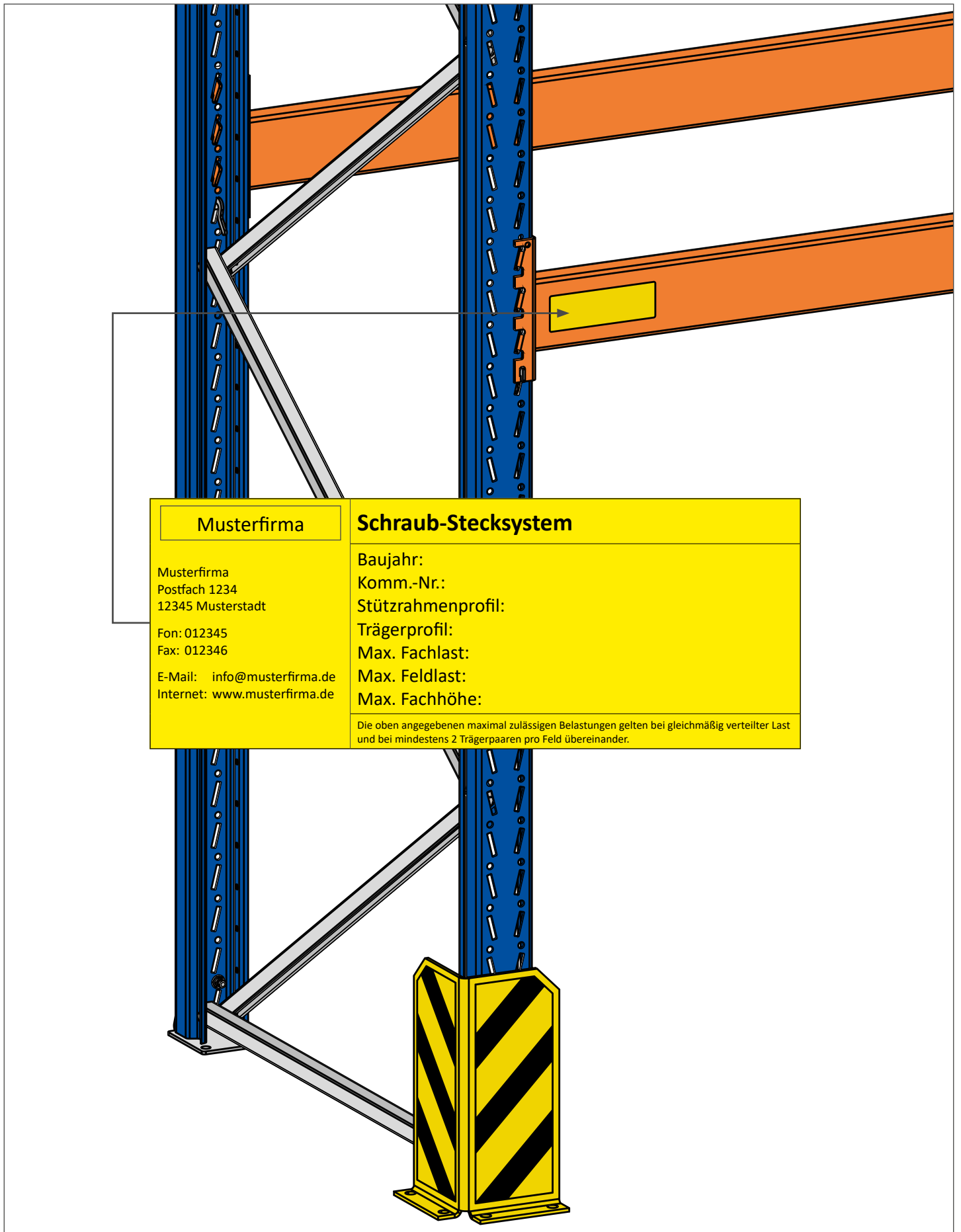

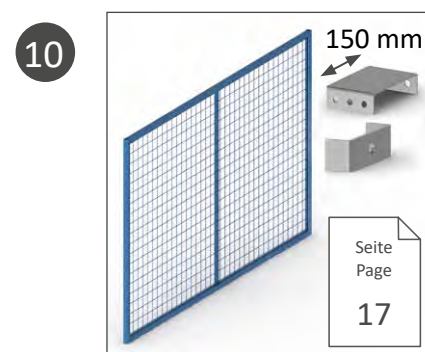
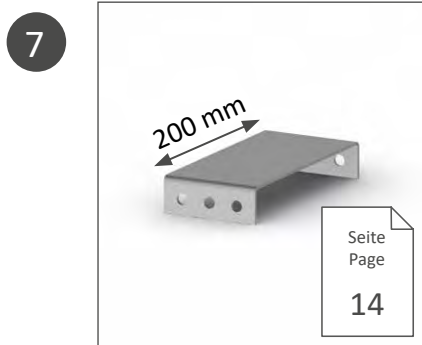
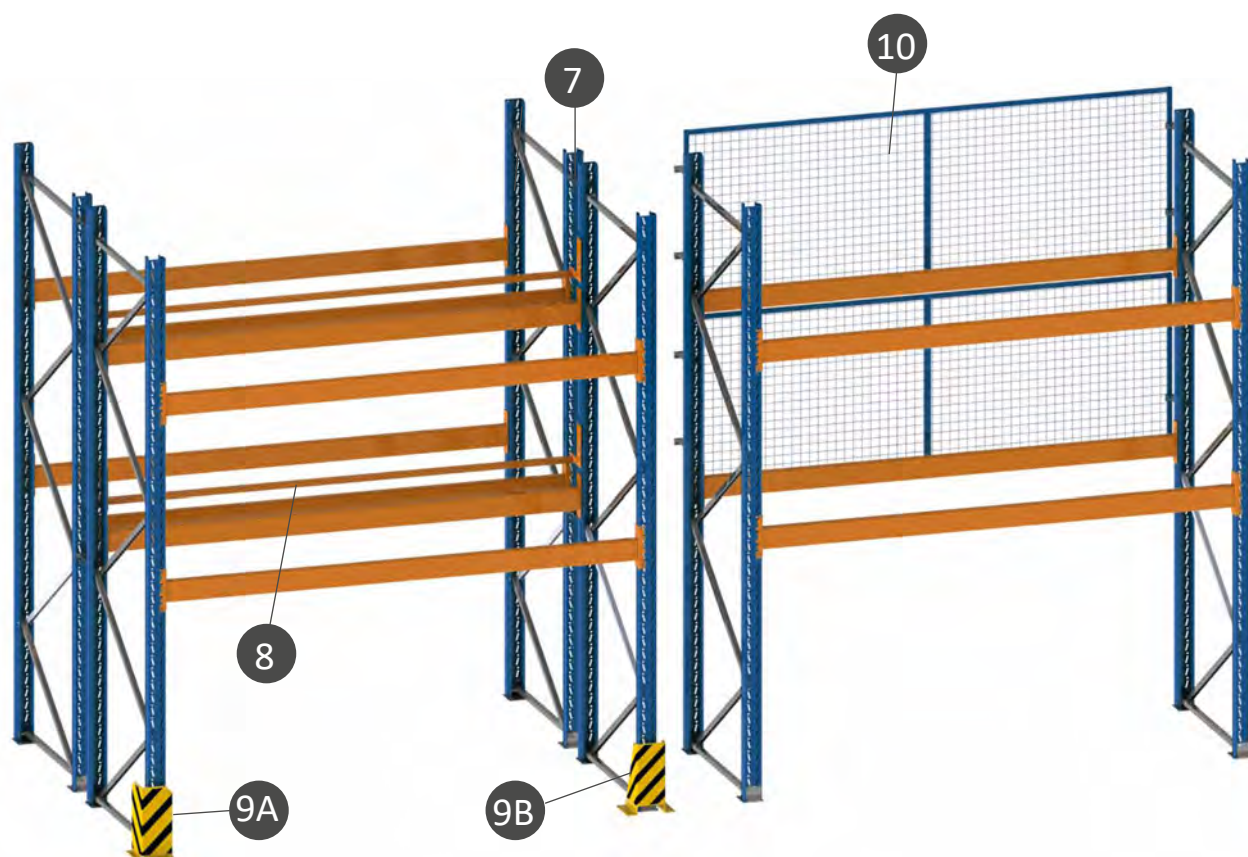

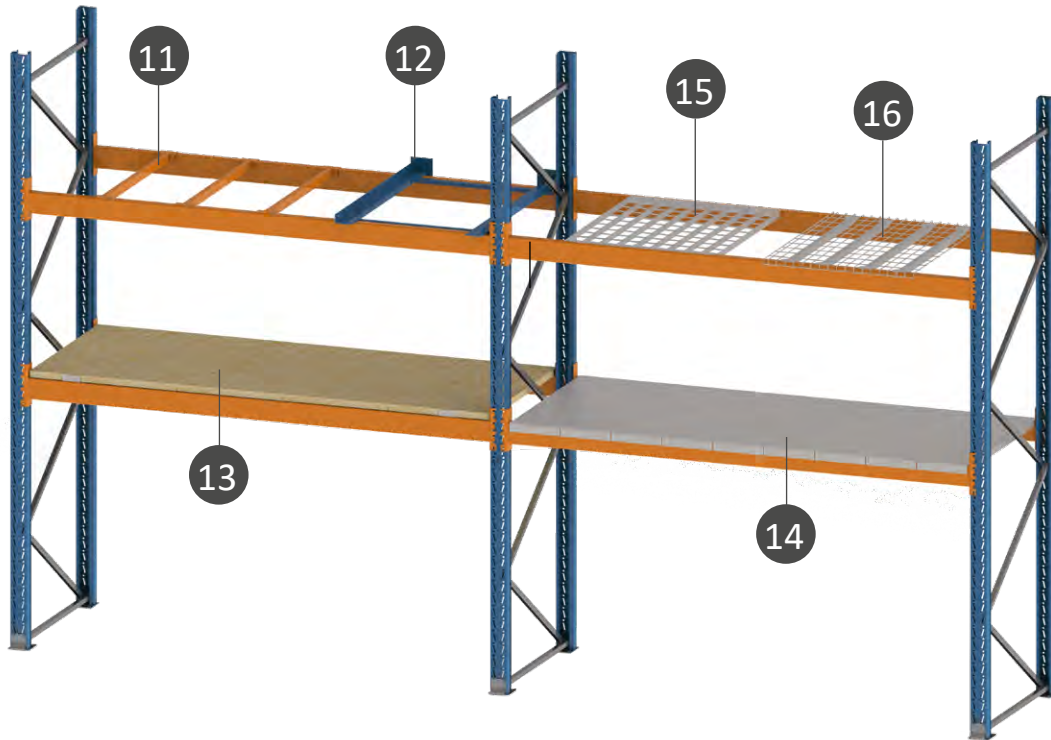

11

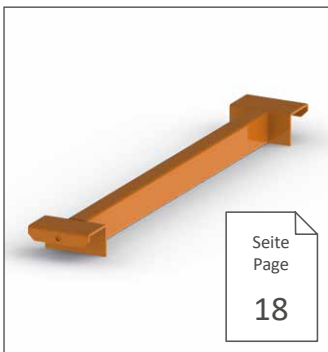

12

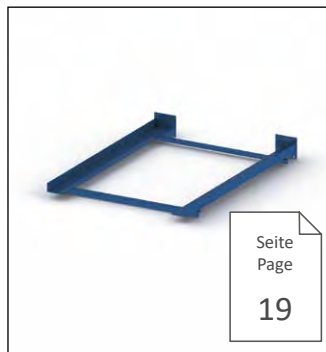

13

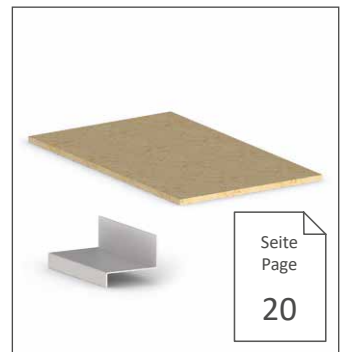

14

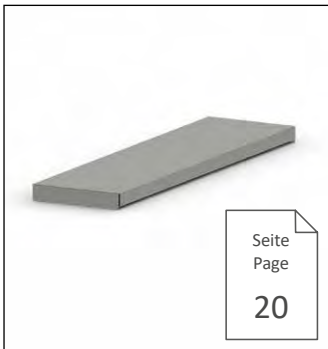

15

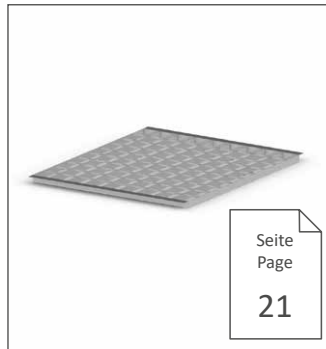

16



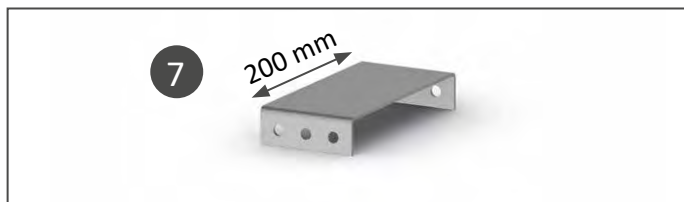

	M10 x 25 mm	 54 Nm
	M10	

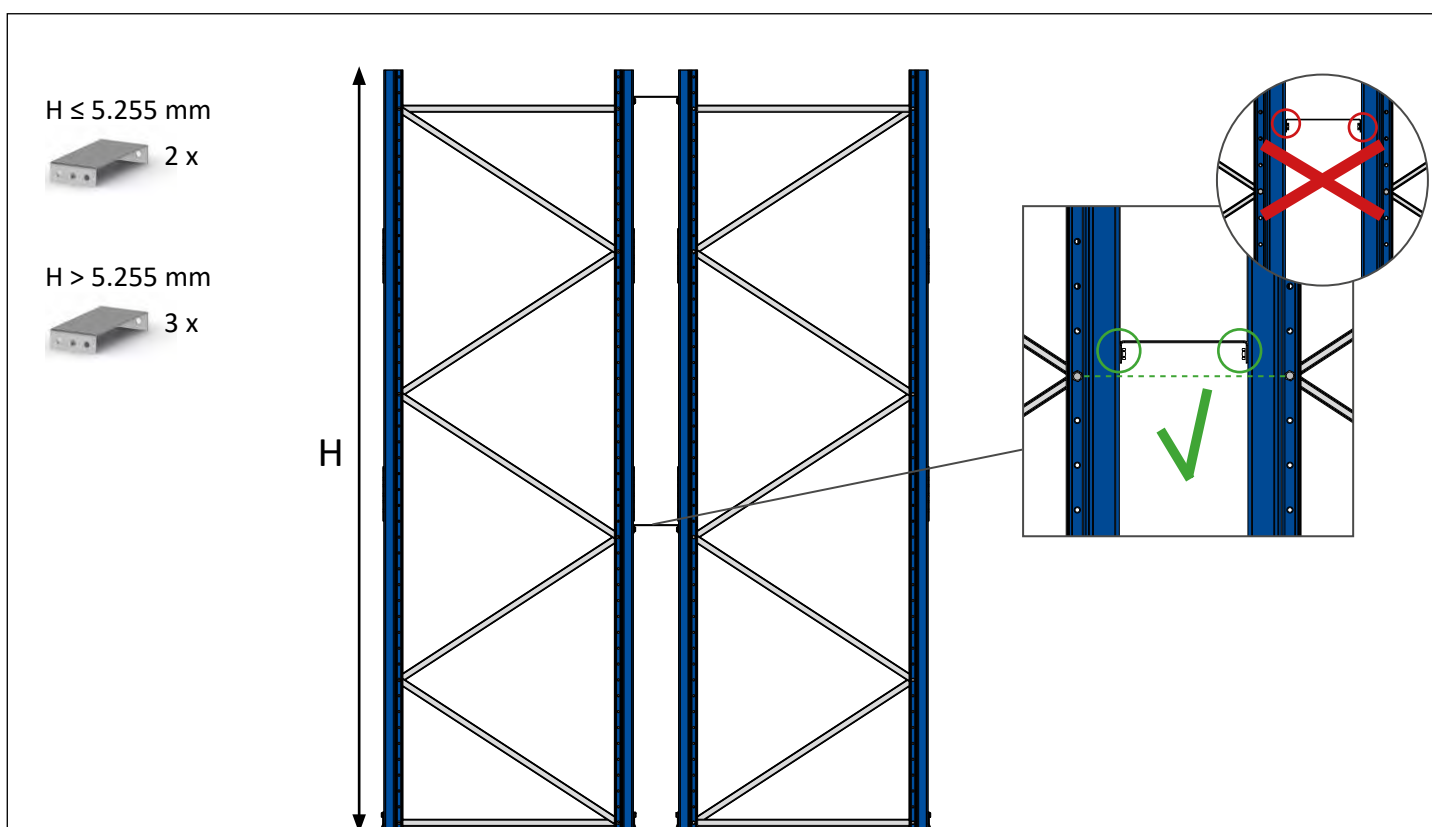
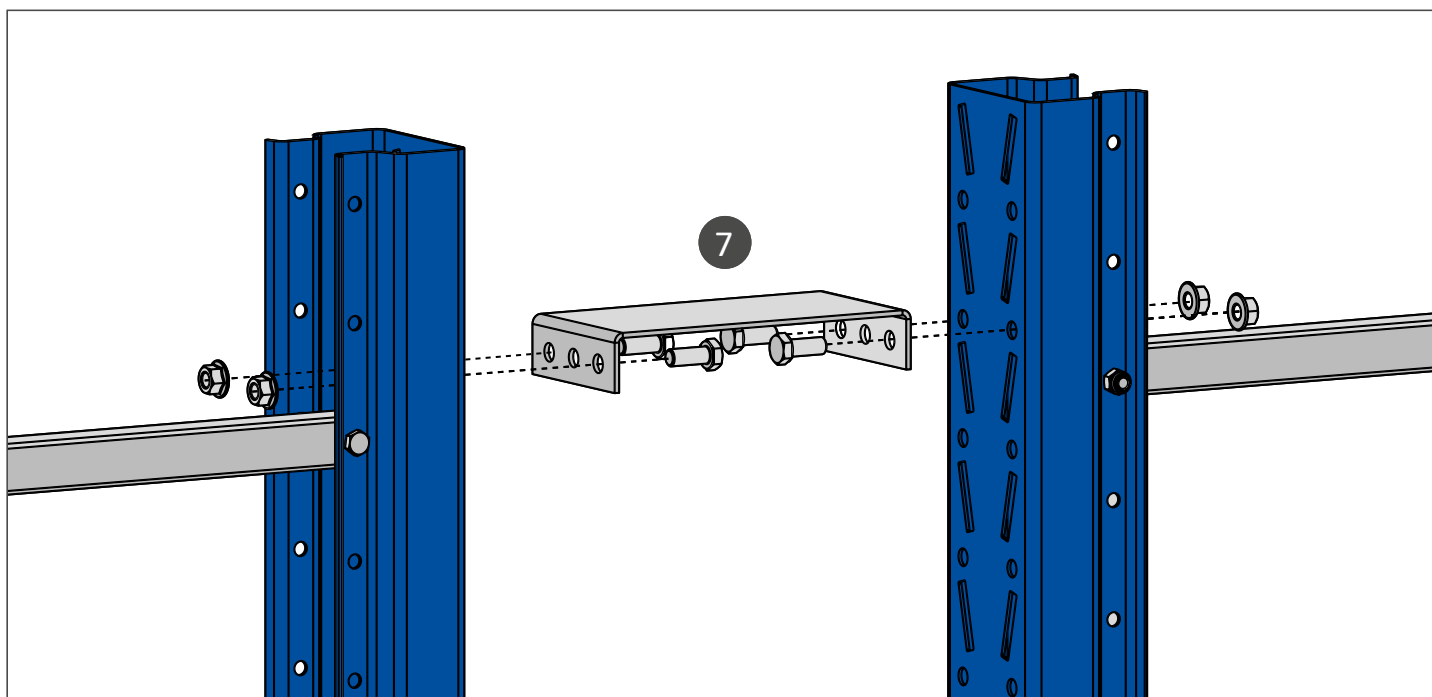

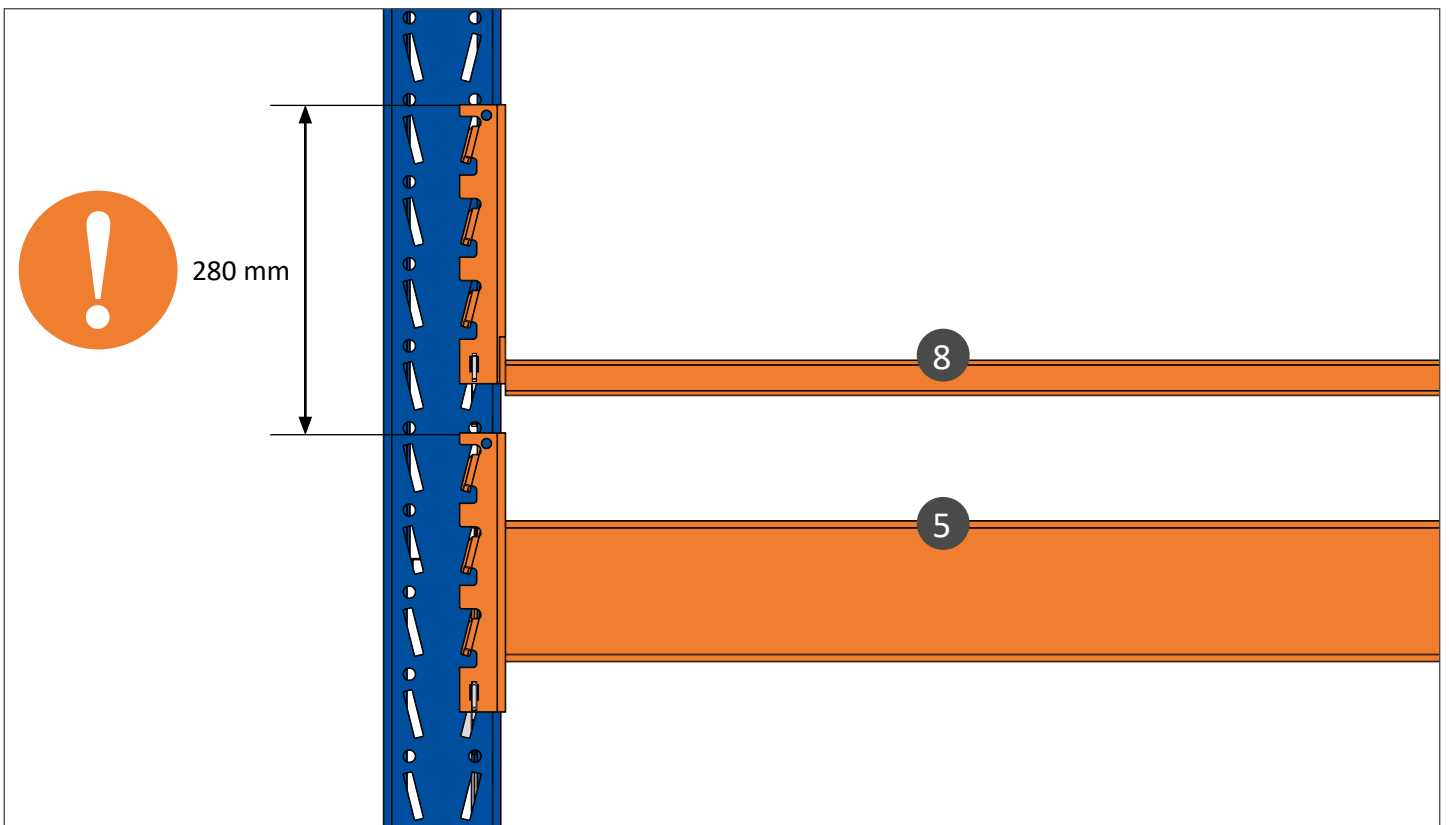
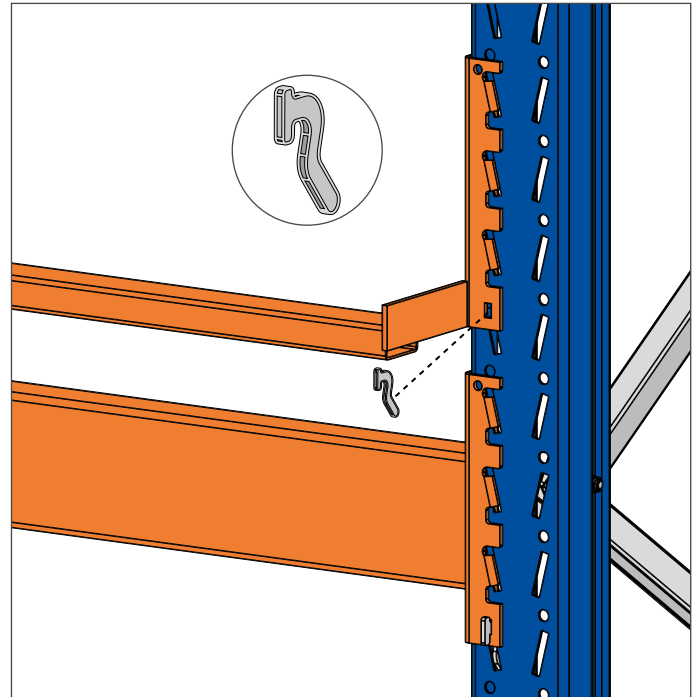
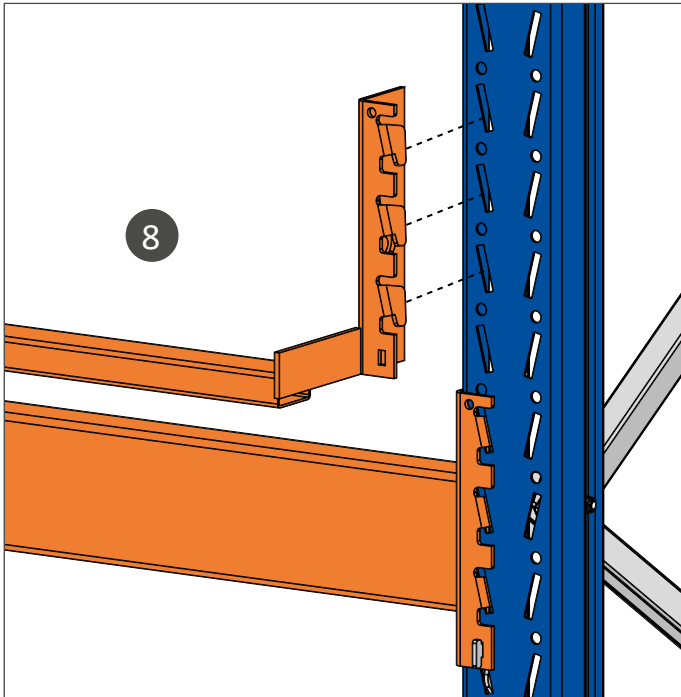

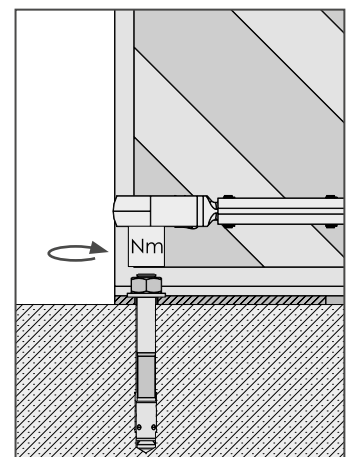
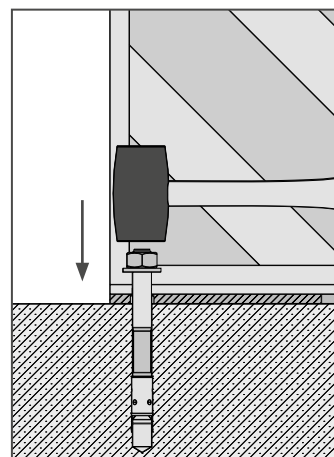
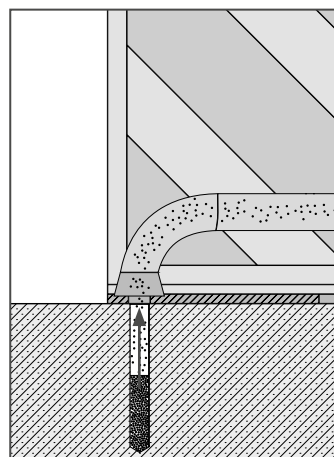
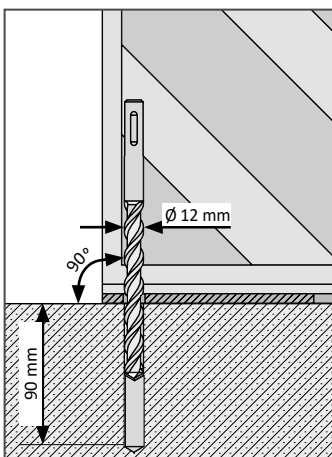
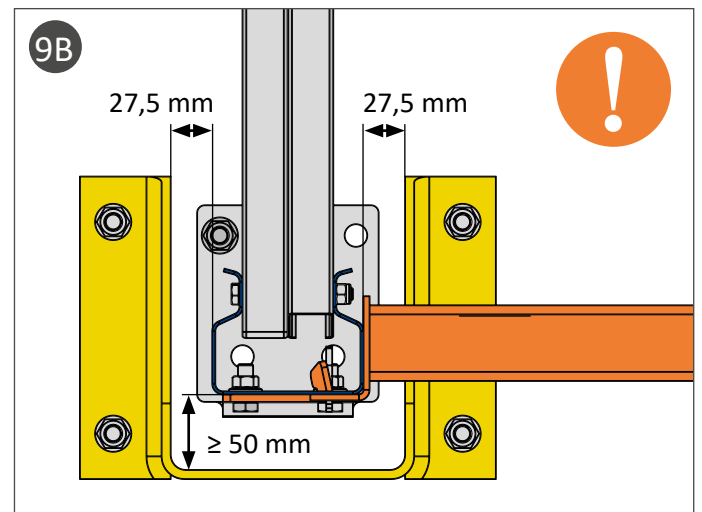
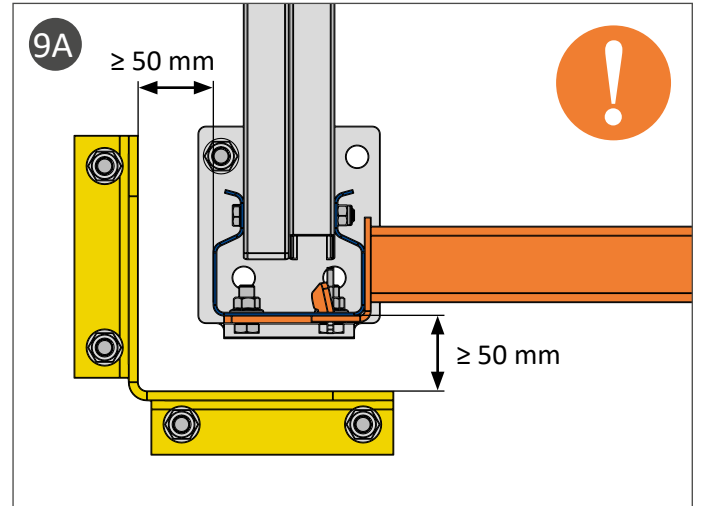
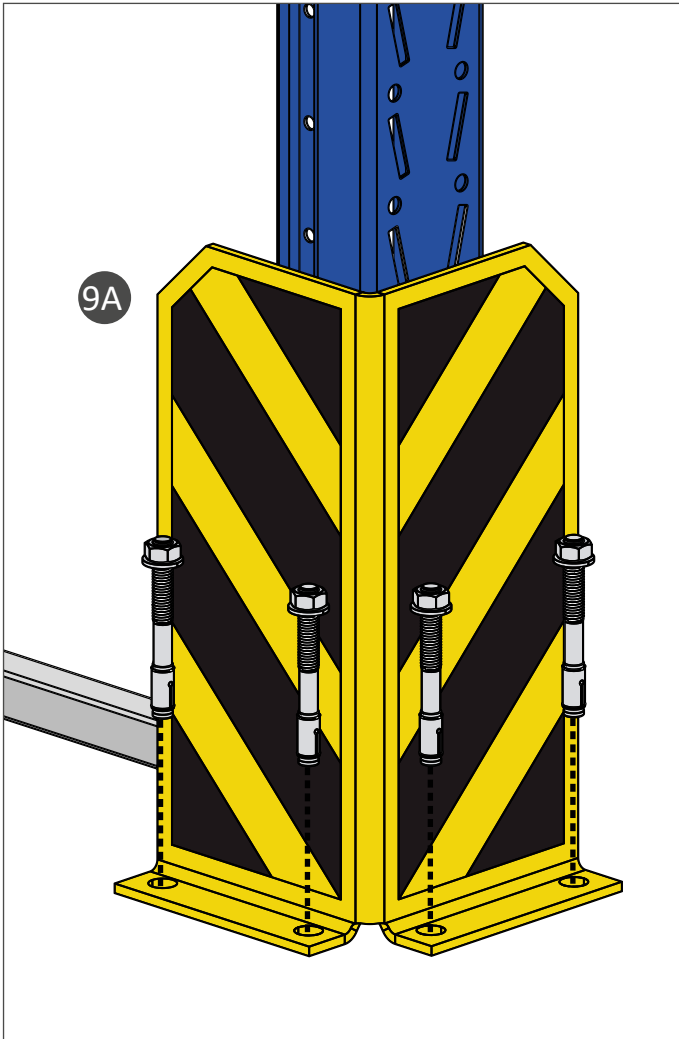
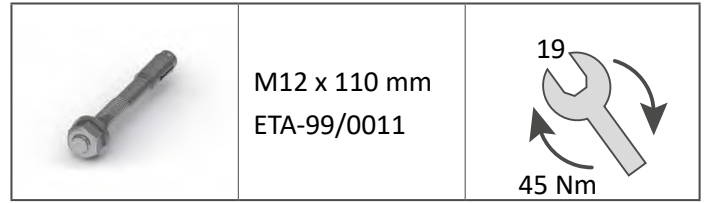

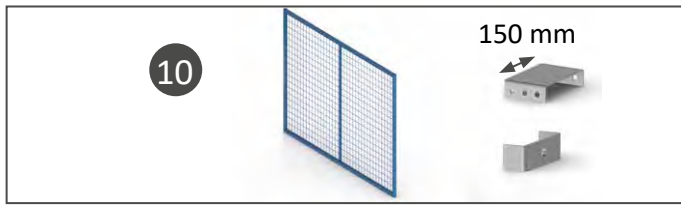

1		M10 x 25 mm	15 16
		M10	
2		M10 x 50 mm	1 54 Nm 2 ≈10 Nm
		M10	

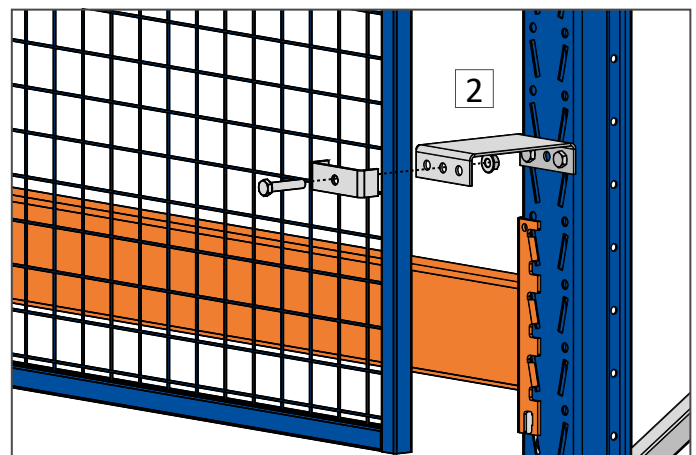
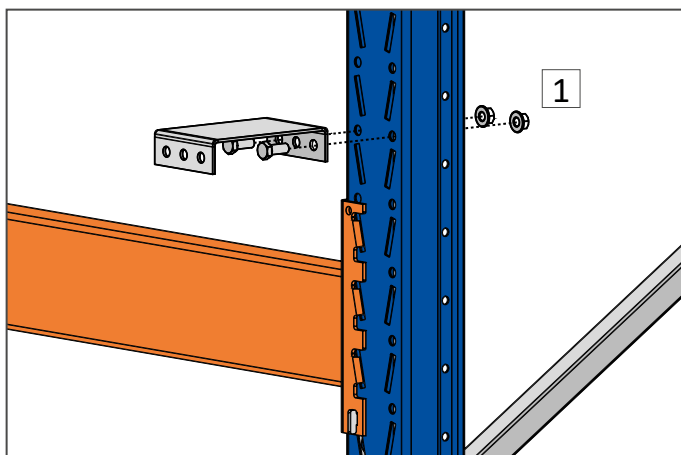
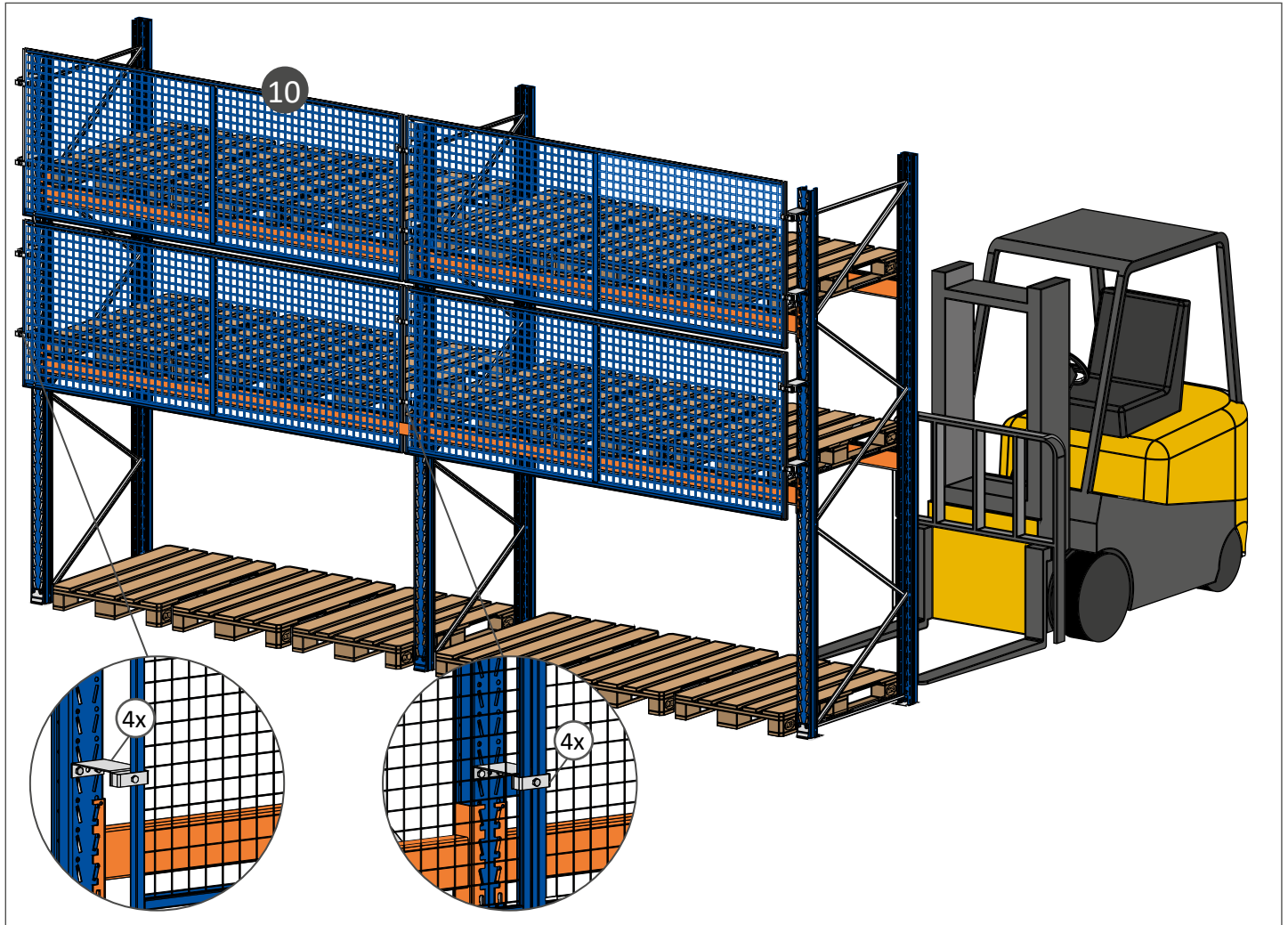

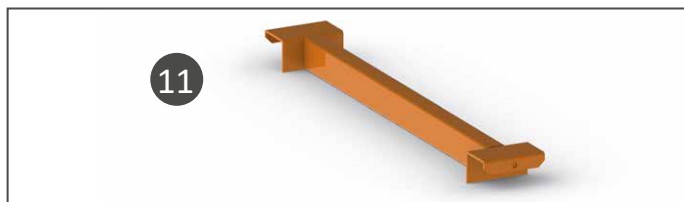

EPAL 800 mm x 1200 mm

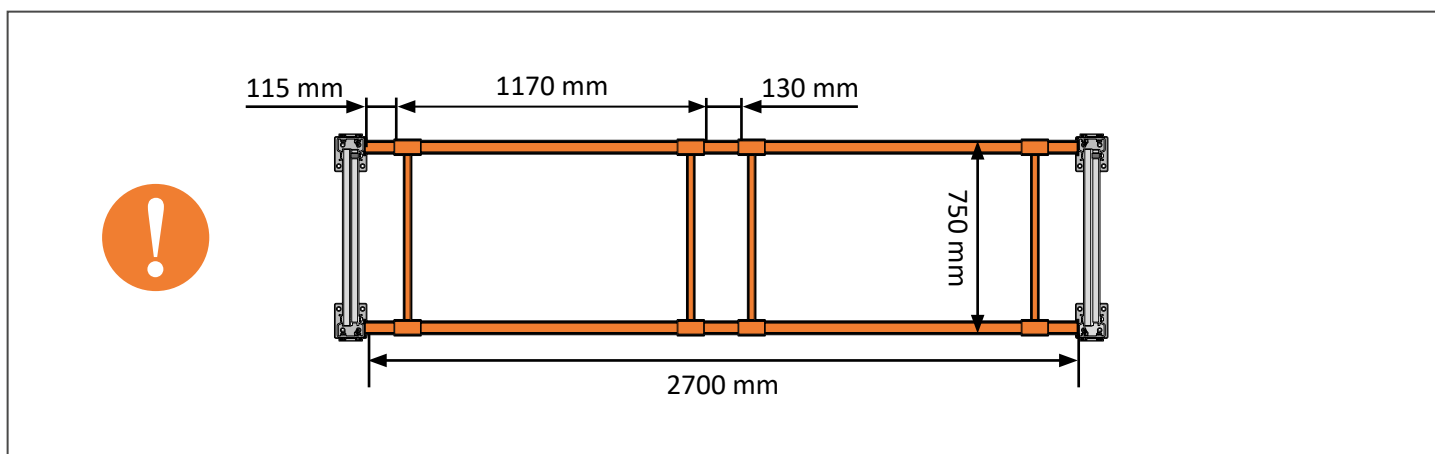

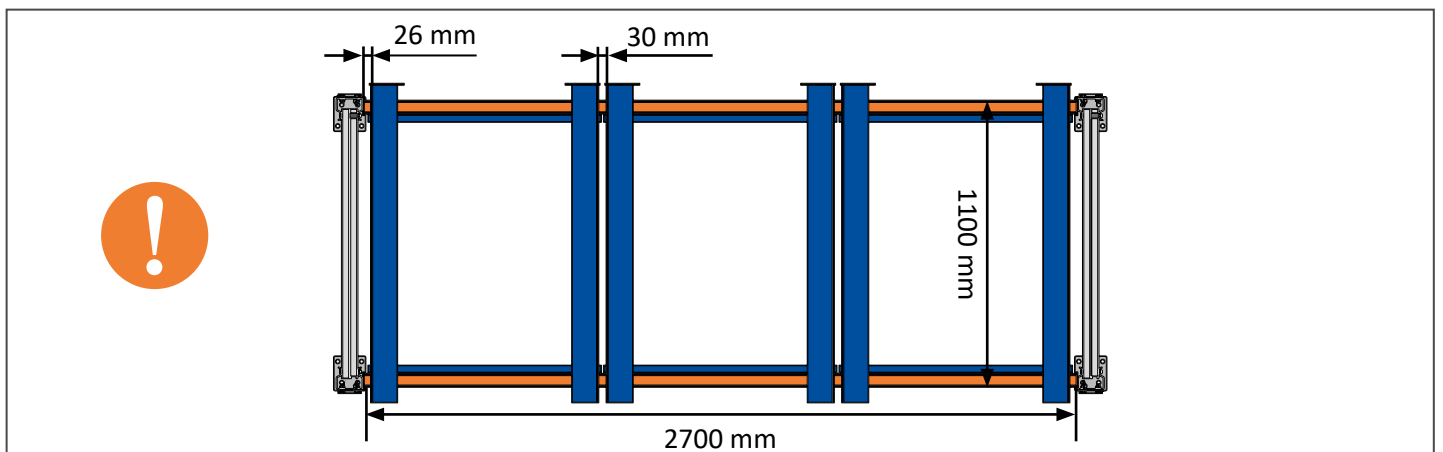
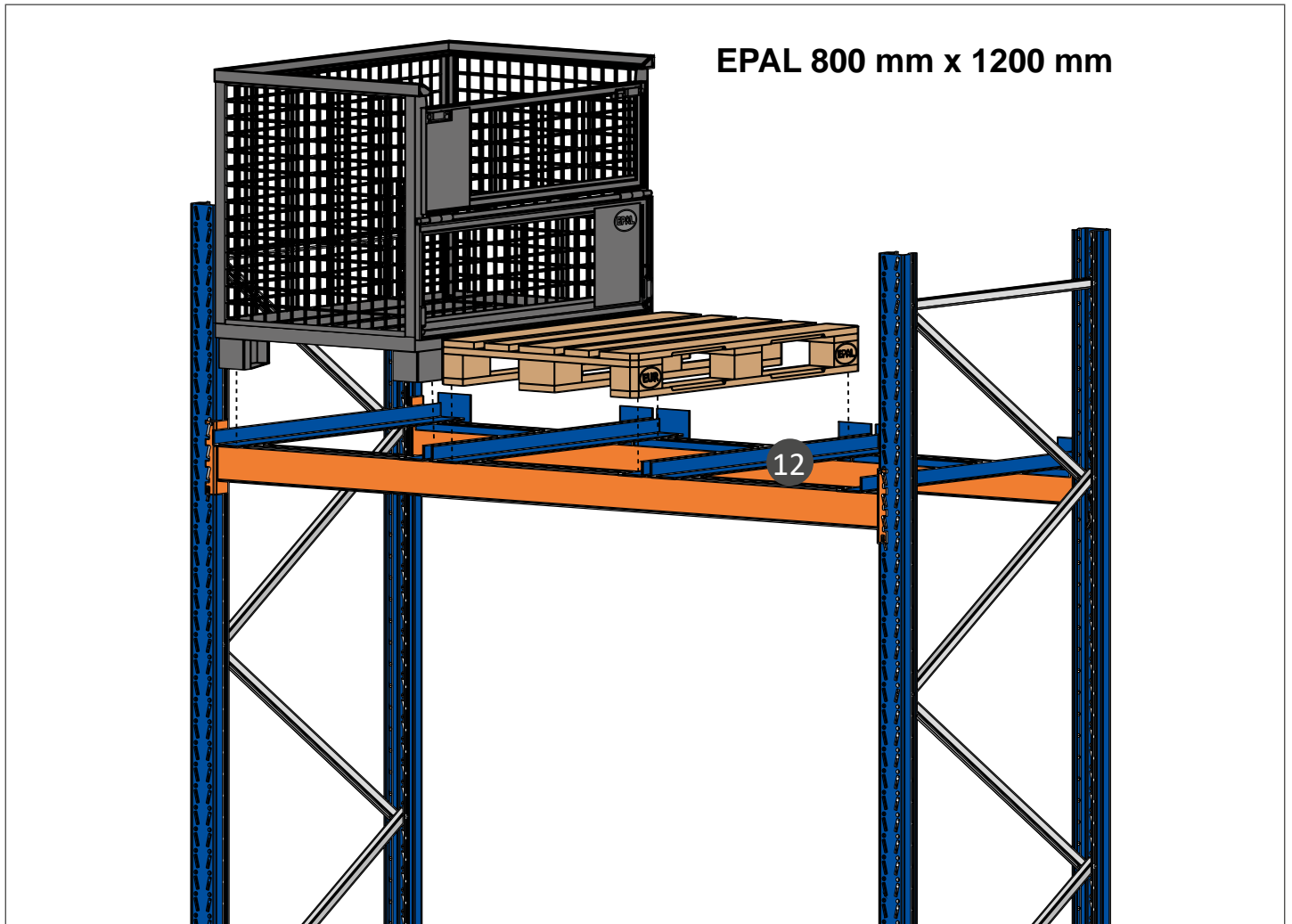
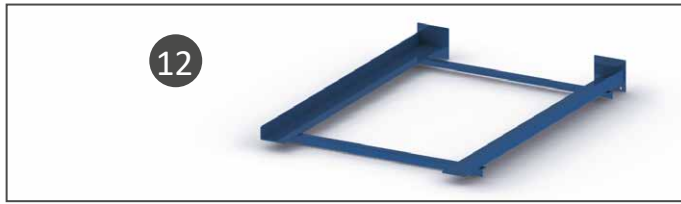

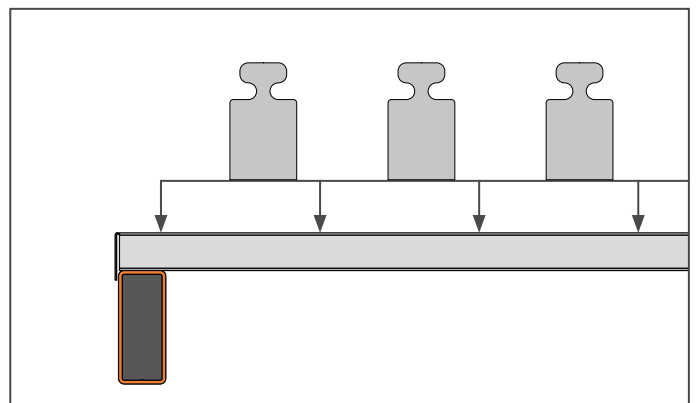
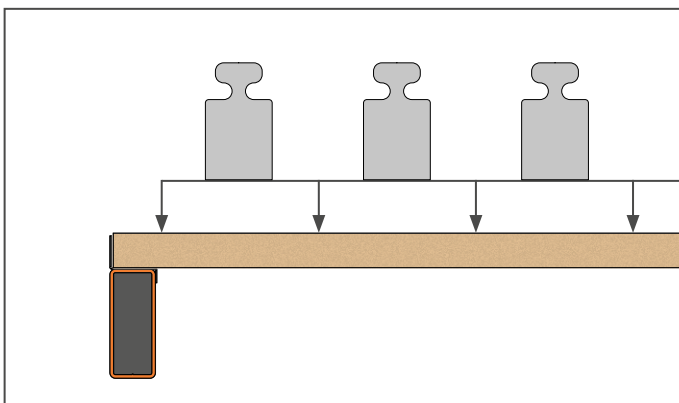
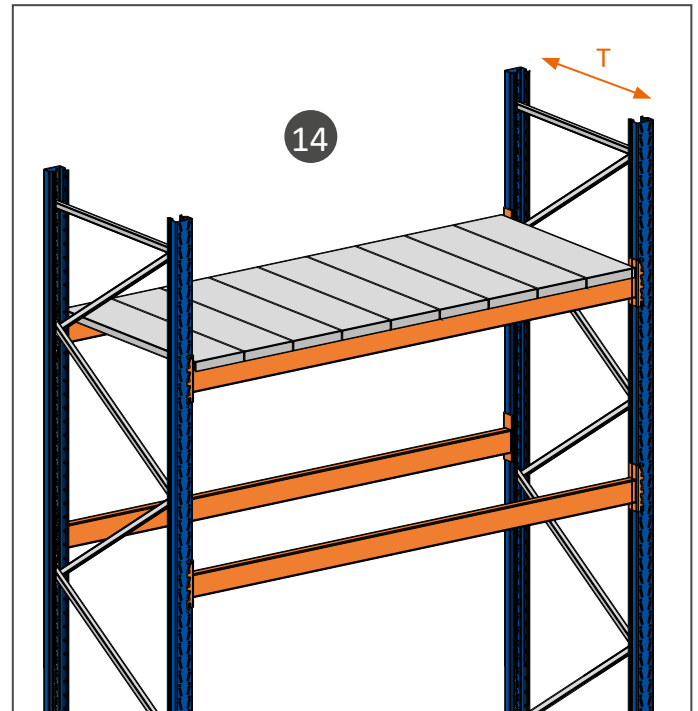
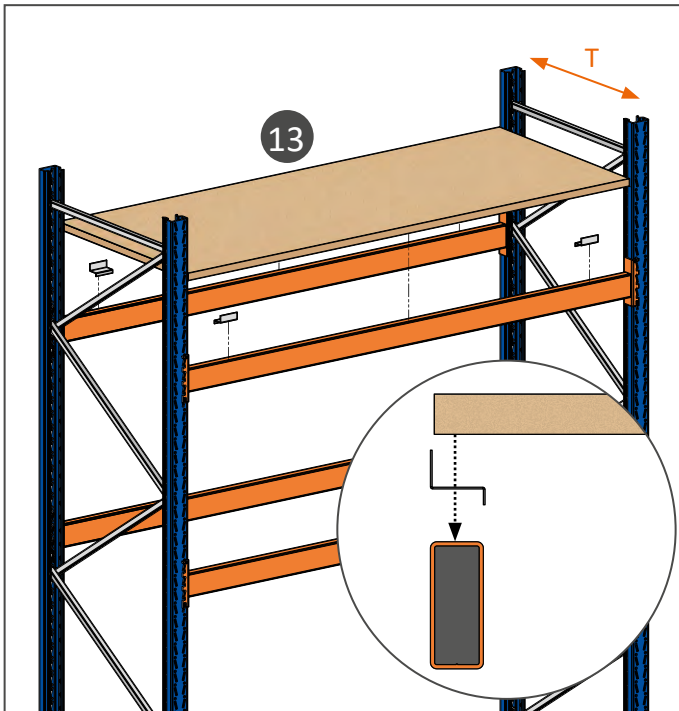

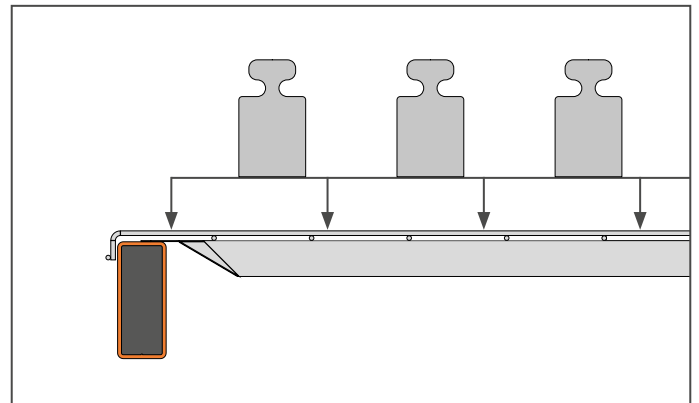
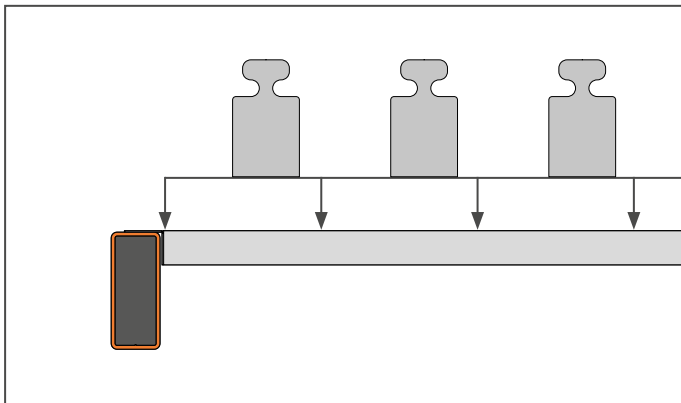
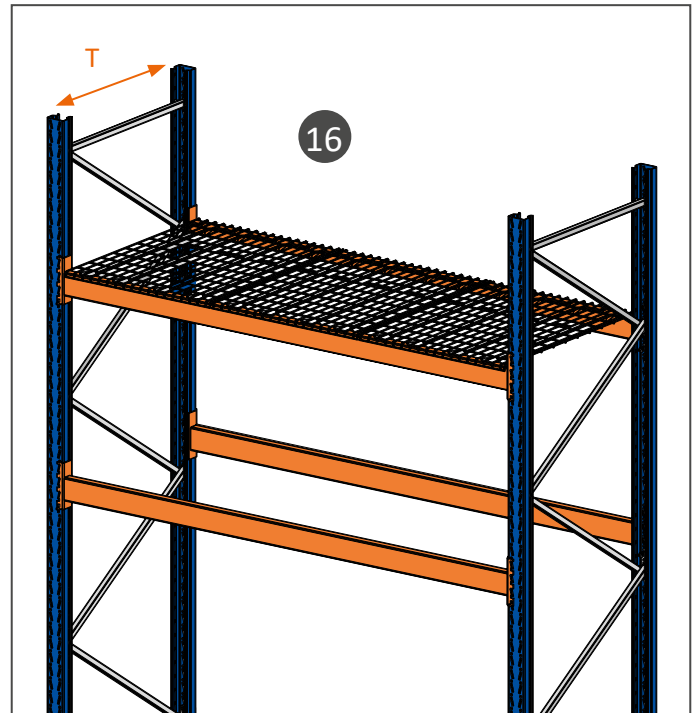
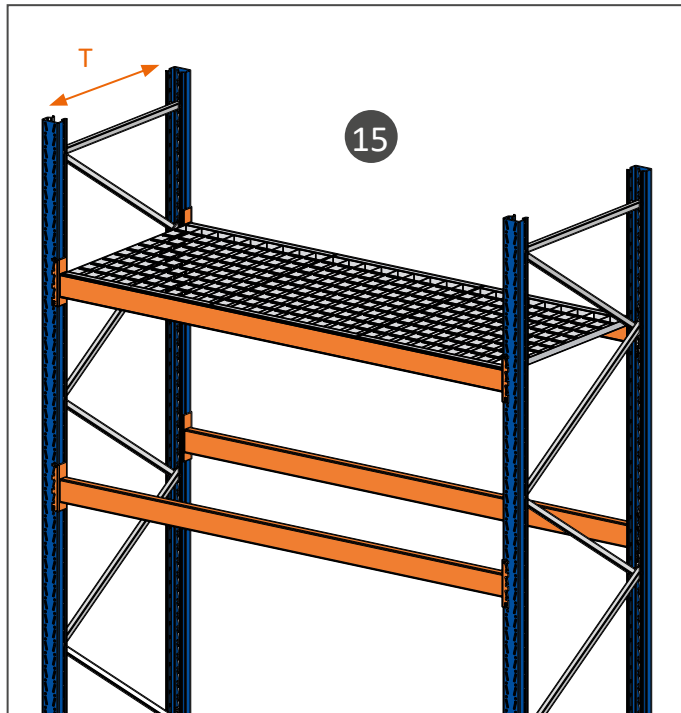
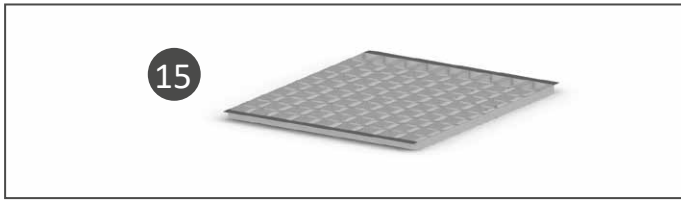

		
B = 2700 mm		
T = 750 mm	≤ 1075 kg	≅ ≤ 650 kg / m ²
T = 900 mm	≤ 825 kg	≅ ≤ 400 kg / m ²
T = 1100 mm	≤ 900 kg	≅ ≤ 350 kg / m ²
B = 1825 mm		
T = 750 mm	≤ 725 kg	≅ ≤ 650 kg / m ²
T = 900 mm	≤ 550 kg	≅ ≤ 400 kg / m ²
T = 1100 mm	≤ 600 kg	≅ ≤ 350 kg / m ²

		
B = 300 mm		
T = 750 mm	≤ 450 kg	≅ ≤ 2000 kg / m ²
T = 900 mm	≤ 350 kg	≅ ≤ 1275 kg / m ²
T = 1100 mm	≤ 300 kg	≅ ≤ 900 kg / m ²

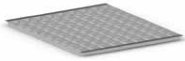
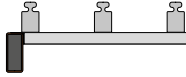

		
	B = 900 mm	
T = 750 mm	≤ 1300 kg	≅ ≤ 2300 kg / m ²
T = 900 mm	≤ 1050 kg	≅ ≤ 1500 kg / m ²
T = 1100 mm	≤ 900 kg	≅ ≤ 1000 kg / m ²

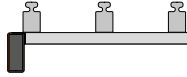
		
	B = 900 mm	
T = 1100 mm	≤ 1000 kg	≅ ≤ 1100 kg / m ²

D Wichtige Sicherheitshinweise



- Erdbeben-, Wind- und Schneelasten sowie Brandschutzvorkehrungen sind unberücksichtigt. Die Palettenregale dürfen nur in geschlossenen Räumen aufgestellt werden. Bei Aufstellung innerhalb einer Erdbebenzone muss herstellerseitig eine statische Dimensionierung des Regals erfolgen.
- Palettenregale müssen im Fußboden verankert werden. Eine Aufstellung ist nur auf Betonböden (Mindestgüte C20/25 mit entsprechender Bewehrung) mit einer Mindestdicke der Bodenplatte von 200 mm und einer Mindestbohrlochtiefe von 150 mm zulässig. Asphalt-, Schotterböden, Verbundsteinpflaster und Betonböden mit Fußbodenheizung sind nicht bzw. nur eingeschränkt geeignet.
- Der Fußboden am Aufstellort muss in der Lage sein die aus der Beladung der Regale entstehenden Lasten (Eigengewicht + Beladung + Zugkraft) sicher aufzunehmen. Bei magnesitgebundenen Fußböden muss mit Kunststoffplatten unterlegt werden, um eine Korrosion der Fußplatten zu vermeiden.
- Das Klettern auf oder in die Regale ist verboten.
- Zur Absturzsicherung müssen die äußeren Regalrahmen mindestens 500 mm höher sein als die oberste Lagerebene.
- Gänge zwischen den Regalanlagen müssen eine ausreichende Breite aufweisen, sodass Flurförderzeuge eine 90°-Drehung durchführen und ein- und auslagern können.
- Verkehrswege bzw. Nebengänge sind mit einer Mindestbreite von 1250 mm bzw. 750 mm auszulegen.
- Die lichte Höhe bei Durchfahrten muss mindestens 2000 mm betragen.
- Bei Außenrahmen und Durchfahrten sind Anfahrsschutze zu montieren.
- Durchfahrten und Überbauten müssen mit einer geeigneten Fachabdeckung gegen Herunterfallen von Lagergütern gesichert sein.
- Jedes Regalfeld wird mit mindestens 2 Trägerpaaren übereinander ausgestattet.
- Alle Fächer eines Regals weisen bei voller Beladung des Regals dieselbe Fachlast auf.
- An jeder Regalzeile sind die mitgelieferten Traglastschilder anzubringen.
- Die Trägerabstände in einem Regalfeld dürfen sich max. um den Faktor 1,2 unterscheiden.
- Die Palettenregale sind in der Reihenfolge von unten nach oben gleichmäßig mit direkter, senkrechter Lasteinleitung in die Auflageträger und symmetrischer Einlagerung zu beladen.
- Seitliches Bewegen von Paletten innerhalb des Regals, Verschieben von Paletten auf den Auflageträgern sowie stoßartiges Absetzen von Paletten auf die Auflageträger ist unzulässig.
- Die Ständerrahmen sind werkseitig nicht zum Tragen von Bauwerkslasten geeignet.
- Der Mindestwandabstand der Palettenregale beträgt 150 mm.
- Verformungen an den Ständerrahmen infolge von Anfahren mit dem Flurförderzeug oder dem Ladungsgut müssen hinsichtlich einer Gefahrenbeurteilung gemäß DIN EN 15635 überprüft werden. Je nach Schadensumfang müssen entsprechende Maßnahmen (z.B. Regal entladen, Regal sperren, Bauteile austauschen) eingeleitet werden.
- Durch Anfahren beschädigte Träger sowie Träger mit beschädigten Einhängeklauen oder Schweißnähten (z.B. durch Risse) müssen ausgetauscht werden.
- **Eigenmächtige Reparaturen ohne Zustimmung des Herstellers bzw. ohne Originalbauteile sind verboten.**
- Es dürfen nur einwandfreie und unbeschädigte Paletten und Gitterboxen im Regal eingesetzt werden. Wenn Beschädigungen gemäß DIN EN ISO 18613 auftreten, ist die betroffene Palette umgehend auszutauschen bzw. zu reparieren, da die nötige Tragfähigkeit nicht mehr gewährleistet ist.
- Gitterboxen dürfen nur in Gitterboxauflagen abgesetzt werden, nicht direkt auf die Träger.
- Einzelregale, die frei im Raum stehen, benötigen Giterrückwände gegen Herabfallen des Lagergutes.
- Bei gewerblich genutzten Regalsystemen muss jährlich eine Regalinspektion nach DIN EN 15635 und DGUV Regel 108-007 von einer fachkundigen Person durchgeführt werden.
- Weiterführende Literatur:
 - DGUV Regel 108-007 – Lagereinrichtungen und -geräte
 - DIN 18202 – Toleranzen im Hochbau – Bauwerke
 - DIN EN 15512 – Ortsfeste Regalsysteme aus Stahl - Verstellbare Palettenregale - Grundlagen der statischen Bemessung
 - DIN EN 15635 – Ortsfeste Regalsysteme aus Stahl - Anwendung und Wartung von Lagereinrichtungen
 - DIN EN ISO 18613 – Paletten für die Handhabung von Gütern - Reparatur von Flachpaletten aus Holz

F Consignes de sécurité importantes



- Les charges dues aux tremblements de terre, au vent et à la neige ainsi que les mesures de protection contre l'incendie ne sont pas prises en compte. Les rayonnages à palettes ne peuvent être installés que dans des locaux fermés. Lorsqu'il est installé dans une zone sismique, le rayonnage doit être dimensionné statiquement par le fabricant.
- Les rayonnages à palettes doivent être ancrés au sol. L'installation n'est autorisée que sur des sols en béton (qualité minimale C20/25 avec preuve de performance correspondante) avec une épaisseur minimale de la plaque de base de 200 mm et une profondeur minimale de perçage de 150 mm. L'asphalte, les sols en gravier, les pavés en pierre composite et les sols en béton avec chauffage par le sol ne conviennent pas ou seulement dans une mesure limitée.
- Le sol du lieu d'installation doit pouvoir absorber en toute sécurité les charges résultant du chargement des rayonnages (poids propre + chargement + force de traction). Dans le cas des sols à base de magnésite, des plaques en plastique doivent être posées en dessous pour empêcher la corrosion des plaques de base.
- Il est interdit de grimper sur ou dans les étagères.
- Pour la protection contre les chutes, les cadres extérieurs des étagères doivent être au moins 500 mm plus hauts que le niveau de stockage le plus élevé.
- Les allées entre les systèmes de rayonnage doivent être suffisamment larges pour permettre aux chariots de manutention de pivoter à 90° et de stocker et récupérer les marchandises.
- Les voies de circulation ou les allées latérales doivent être conçues avec une largeur minimale de 1250 mm ou 750 mm.
- La hauteur libre des passages doit être d'au moins 2000 mm.
- Les cadres extérieurs et les passages doivent être équipés de protections anti-collision.
- Les passages et structures en hauteur doivent être sécurisés par un couvercle ou panneau approprié afin d'éviter que les marchandises stockées ne tombent.
- Chaque étagère est équipée d'au moins 2 paires de longerons superposées.
- Tous les compartiments d'un rayonnage ont la même charge lorsque le rayonnage est entièrement chargé.
- Les plaques de charge fournies doivent être fixées sur chaque ligne de rayonnage.
- Les distances entre les supports dans un rayonnage peuvent varier d'un facteur maximum de 1,2.
- Les rayonnages à palettes doivent être chargés uniformément du bas vers le haut avec une introduction directe et verticale de la charge dans les longerons et un stockage symétrique.
- Le déplacement latéral des palettes à l'intérieur du rayonnage, le déplacement des palettes sur les longerons ainsi que le dépôt par à-coups des palettes sur les longerons ne sont pas autorisés.
- Les cadres verticaux ne sont pas adaptés en usine pour supporter des charges structurelles de bâtiment.
- La distance minimale entre les rayonnages à palettes est de 150 mm.
- Les déformations des montants, dues à un choc avec le chariot de manutention ou à la charge, doivent être vérifiées dans le cadre d'une évaluation des risques conformément à la norme DIN EN 15635. En fonction de l'ampleur des dommages, des mesures appropriées (par ex. le déchargement ou le verrouillage des étagères, le remplacement des composants) doivent être prises.
- Les longerons endommagés par un choc et les longerons dont les griffes de suspension ou les soudures sont endommagées (en raison de fissures, par ex.) doivent être remplacés.
- **Les réparations non autorisées sans le consentement du fabricant ou sans les composants d'origine sont interdites.**
- Seules des palettes et des caisses-palettes en parfait état et non endommagées peuvent être utilisées dans le rayonnage. En cas de dommage selon la norme DIN EN ISO 18613, la palette concernée doit être remplacée ou réparée immédiatement, car la capacité de charge nécessaire n'est plus garantie.
- Les caisses-palettes ne peuvent être déposées que dans des supports de caisses-palettes et non directement sur les longerons.
- Les rayonnages simples, disposés de façon autonome dans la pièce, nécessitent des murs arrière grillagés pour empêcher les marchandises stockées de tomber.
- Pour les systèmes de rayonnage utilisés dans le commerce, un contrôle annuel des rayonnages selon la norme DIN EN 15635 et le règlement 108-007 de la DGUV doit être effectué par une personne compétente.
- Lectures complémentaires :
 - Règlement 108-007 de la DGUV - Installations et équipements de stockage
 - DIN 18202 – Tolérances dans la construction immobilière – Bâtiments
 - DIN EN 15512 - Systèmes de rayonnages statiques en acier - Rayonnages à palettes réglables - Principes de conception structurelle
 - DIN EN 15635 - Systèmes de rayonnages statiques en acier - Application et entretien des équipements de stockage
 - DIN EN ISO 18613 - Palettes pour la manutention de marchandises - Réparation des palettes plates en bois

Belangrijke veiligheidsinstructies



- Aardbevingen, wind- en sneeuwlasten en brandbeveiligingsmaatregelen zijn buiten beschouwing gelaten. De palletstellingen mogen alleen in gesloten ruimtes worden geplaatst. Bij installatie binnen een aardbevingszone moet de stelling door de fabrikant structureel worden aangepast.
- Palletstellingen moeten aan de vloer worden verankerd. Installatie is alleen toegestaan op betonvloeren (minimale kwaliteit C20/25 met passende bewapening) met een minimale dikte van de bodemplaat van 200 mm en een minimale boorgatdiepte van 150 mm. Asphalt, grindvloeren, stenen bestrating en betonvloeren met vloerverwarming zijn niet of slechts in beperkte mate geschikt.
- De vloer op de plaats van installatie moet de belastingen die voortvloeien uit de belasting van de stellingen (eigen gewicht + belasting + trekkracht) veilig kunnen opvangen. In het geval van magnesienvloeren moeten plastic platen op de vloer worden gelegd om corrosie van de basisplaten te voorkomen.
- Het is verboden om op of in de stellingen te klimmen.
- Voor de valbeveiliging moeten de buitenste stellingframes minstens 500 mm hoger zijn dan het bovenste stellingniveau.
- De gangpaden tussen de stellingen moeten voldoende breed zijn om transportwerktuigen in staat te stellen 90° te draaien en goederen op te slaan en op te halen.
- Verkeerswegen of zijgangen moeten worden ontworpen met een minimumbreedte van 1250 mm of 750 mm.
- De vrije hoogte voor doorgangen moet minstens 2000 mm bedragen.
- Bij buitenframes en doorgangen moeten aanrijbeschermingen worden aangebracht.
- De doorgangen en de bovenbouw moeten met een geschikt compartimentdeksel worden beveiligd tegen het omlaag vallen van opgeslagen goederen.
- Elk legbord is voorzien van minstens 2 paar dragers boven elkaar.
- Alle compartimenten van een stelling hebben dezelfde compartimentbelasting als de stelling volledig is beladen.
- Op ieder legbordrand moeten de meegeleverde draaglastborden worden bevestigd.
- De afstand van de dragers bij een legbord mag maximaal met factor 1,2 afwijken.
- De palletstellingen moeten gelijkmatig in de volgorde van onder naar boven worden geladen met directe, verticale plaatsing van de belasting op de steunbalken en met een symmetrische opslag.
- Zijdelingse verplaatsing van pallets binnen de stelling, het verplaatsen van pallets op de steunbalken en het schokkerig neerzetten van pallets op de steunbalken is niet toegestaan.
- De staande frames zijn niet gebouwd voor het dragen van structurele belastingen.
- De minimale afstand van de palletstellingen tot de wand is 150 mm.
- Vervormingen in de staande frames als gevolg van botsingen met het transportvoertuig of de lading moeten worden gecontroleerd met het oog op een risicobeoordeling volgens DIN EN 15635. Afhankelijk van de omvang van de schade moeten passende maatregelen worden genomen (bijv. stelling leegmaken, stelling vergrendelen, componenten vervangen).
- Balken die beschadigd zijn door stoten en balken met beschadigde ophangklauwen of lasnaden (bijv. door scheuren) moeten worden vervangen.
- **Ongeoorloofde reparaties zonder toestemming van de fabrikant of zonder originele onderdelen zijn verboden.**
- Alleen onbeschadigde en onbeschadigde pallets en roosterboxen mogen in de stelling worden gebruikt. Bij in het geval van schade conform DIN EN ISO 18613 moet de betreffende pallet onmiddellijk worden vervangen of gerepareerd, omdat het vereiste draagvermogen niet meer gegarandeerd is.
- De roosterboxen mogen alleen worden neergezet in roosterboxsteunen, niet direct op de balken.
- Enkele rekken, die vrij in de ruimte staan, hebben roosterachterwanden nodig om te voorkomen dat de opgeslagen goederen naar beneden vallen.
- Voor commercieel gebruikte stellingen moet een jaarlijkse stellingcontrole conform DIN EN 15635 en DGUV-voorschrift 108-007 worden uitgevoerd door een bevoegd persoon.
- Meer lezen:
 - DGUV-voorschrift 108-007 - Opslagfaciliteiten en -apparatuur
 - DIN 18202 – Toleranties in bouwconstructies – Gebouwen
 - DIN EN 15512 - Vaste stalen stellingen - Verstelbare palletstellingen - Grondslagen van de constructie
 - DIN EN 15635 - Vaste stalen stellingen - Toepassing en onderhoud van opslagapparatuur
 - DIN EN ISO 18613 - Pallets voor de behandeling van goederen - Reparatie van vlakke houten pallets

GB Important safety information



- Earthquake, wind and snow loads as well as fire protection measures are not taken into account. The pallet racks may only be installed in closed rooms. When installed within an earthquake zone, the shelving unit must be dimensioned statically by the manufacturer.
- Pallet racks must be anchored to the floor. Installation is only permitted on concrete floors (minimum quality C20/25 with corresponding proof of performance) with a minimum thickness of the base plate of 200 mm and a minimum drill hole depth of 150 mm. Asphalt, gravel floors, composite stone paving and concrete floors with underfloor heating are not suitable or only suitable to a limited extent.
- The floor at the place of installation must be able to safely absorb the loads resulting from the loading of the racks (dead weight + loading + tractive force). In the case of magnesite-bonded floors, plastic plates must be underlaid to prevent corrosion of the base plates.
- Climbing on or into the shelves is prohibited.
- For fall protection, the outer shelf frames must be at least 500 mm higher than the topmost storage level.
- Aisles between the racking systems must be sufficiently wide to allow industrial trucks to make a 90° turn and store and retrieve goods.
- Traffic routes or side aisles shall be designed with a minimum width of 1250 mm or 750 mm.
- The clear height for passages must be at least 2000 mm.
- Collision guards must be fitted for outer frames and passageways.
- Passages and superstructures must be secured with a suitable compartment cover to prevent stored goods from falling down.
- Each shelf unit is equipped with at least 2 pairs of beams one above the other.
- All compartments of a rack have the same compartment load when the rack is fully loaded.
- The load plates supplied must be attached to each shelf line.
- The carrier distances in a shelf field may differ by a maximum factor of 1.2.
- The pallet racks must be loaded evenly in the order from bottom to top with direct, vertical load introduction into the support beams and symmetrical storage.
- Lateral movement of pallets within the rack, moving of pallets on the support beams as well as jerky depositing of pallets on the support beams is not permitted.
- The upright frames are not suitable at the factory for carrying structural loads.
- The minimum wall distance of the pallet racks is 150 mm.
- Deformations in the upright frames as a result of impact with an industrial truck or load must be checked with regard to a risk assessment in accordance with DIN EN 15635. Depending on the extent of the damage, appropriate measures (e.g. unloading shelves, locking shelves, replacing components) must be initiated.
- Beams damaged by impact and beams with damaged suspension claws or welded seams (e.g. due to cracks) must be replaced.
- **Unauthorised repairs without the manufacturer's consent or without original components are prohibited.**
- Only faultless and undamaged pallets and mesh pallets may be used in the rack. If damage occurs in accordance with DIN EN ISO 18613, the pallet concerned must be replaced or repaired immediately, as the necessary load-bearing capacity is no longer guaranteed.
- Box pallets may only be set down in grid box supports, not directly on the beams.
- Single racks, which stand freely in the room, require mesh back walls to prevent the stored goods from falling down.
- For commercially used racking systems, an annual rack inspection according to DIN EN 15635 and DGUV Regulation 108-007 must be carried out by a competent person.
- Further reading:
 - DGUV Regulation 108-007 – Storage facilities and equipment
 - DIN 18202 – Tolerances in building construction – Buildings
 - DIN EN 15512 – Steel static storage systems – Adjustable pallet racking systems – Principles for structural design
 - DIN EN 15635 – Steel static storage systems – Application and maintenance of storage equipment
 - DIN EN ISO 18613 – Pallets for materials handling – Repair of flat wooden pallets

(D) Mindestabstände

(F) Distance minimale | (NL) Minimale afstand | (GB) Minimum distance



EPAL 800 mm x 1200 mm

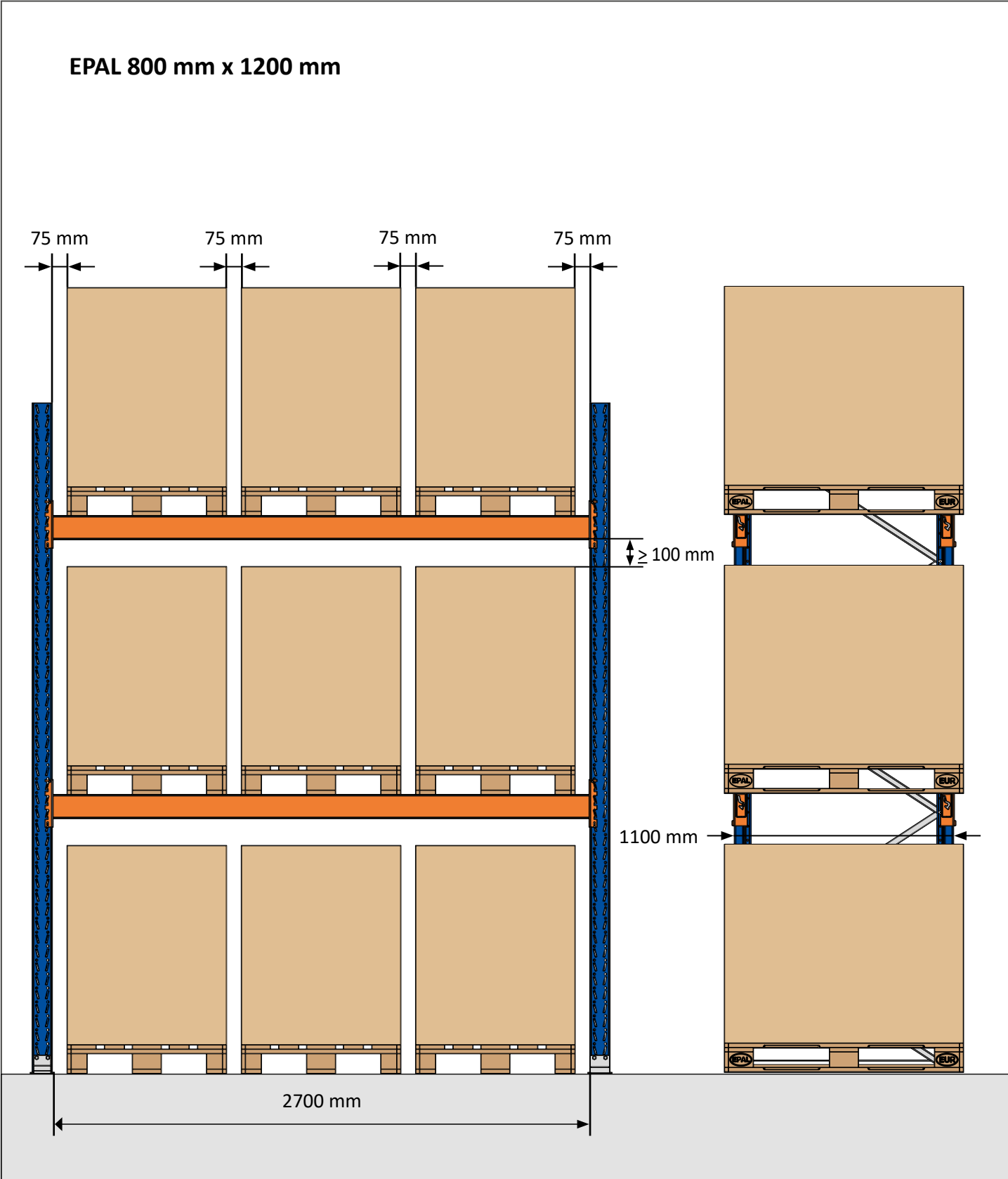

D Durchfahrten

F Passages | NL Doorgangen | GB Passages

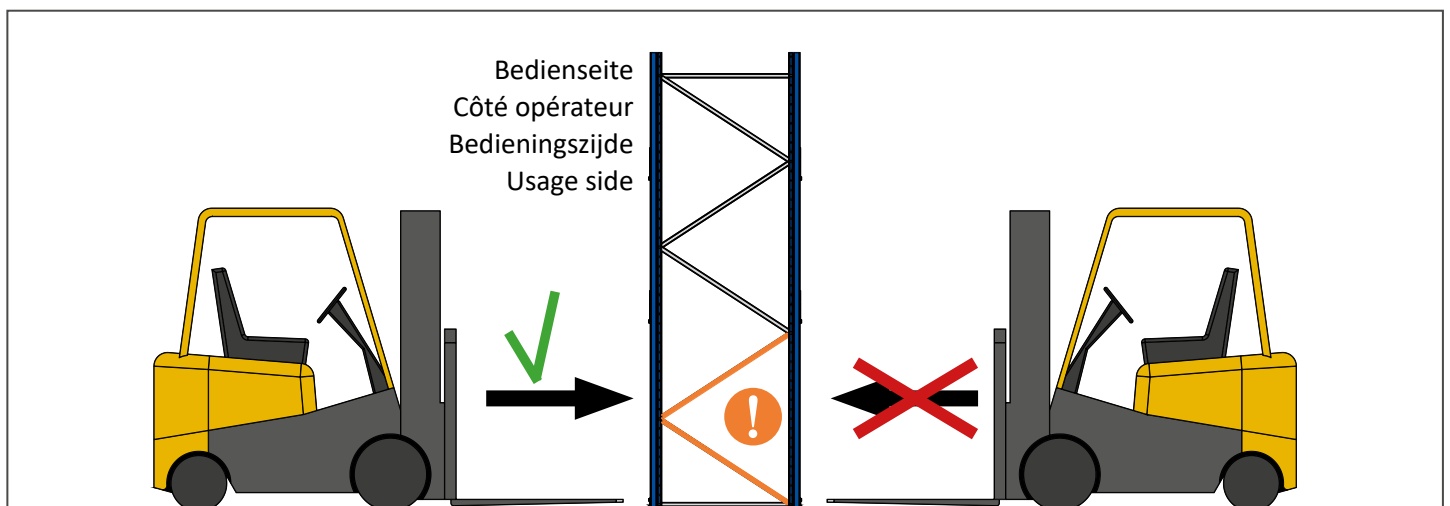
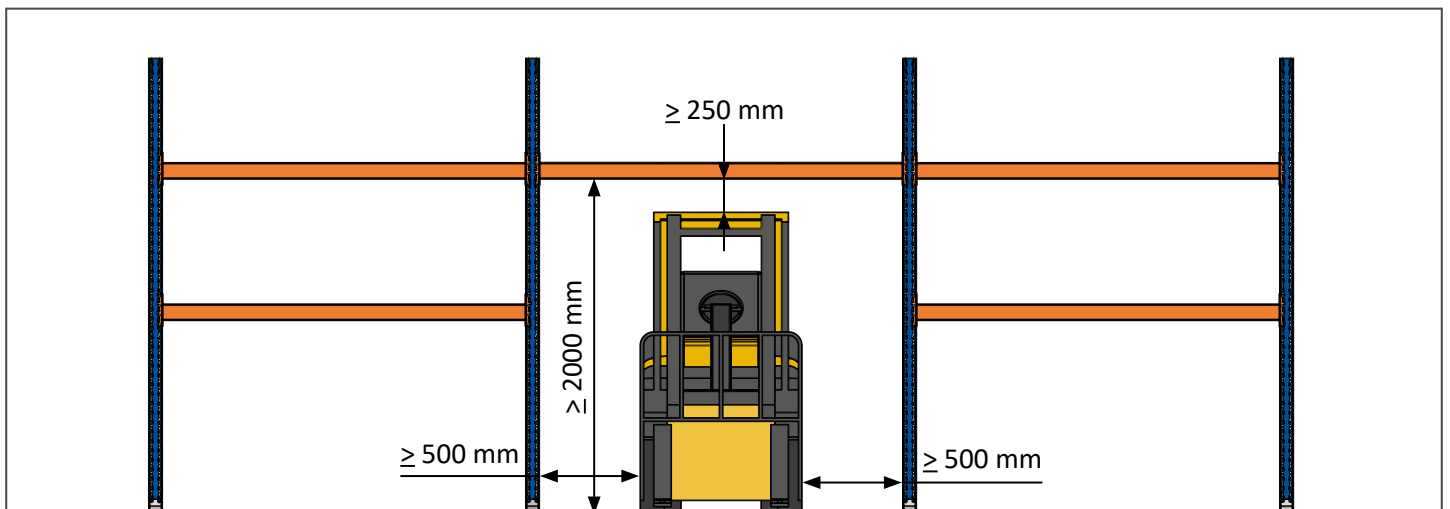
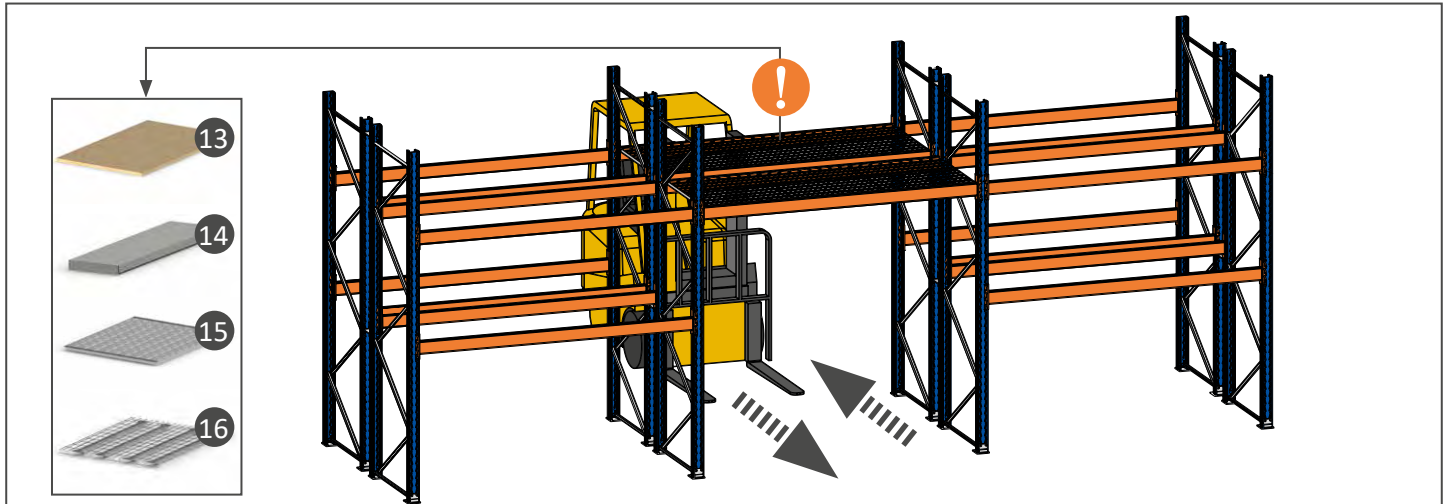

D Belastungsangaben

F Indications de charge

NL Laadgegevens

GB Load data

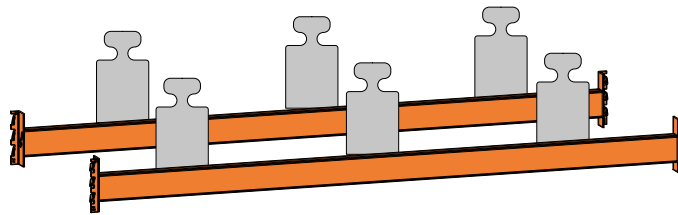
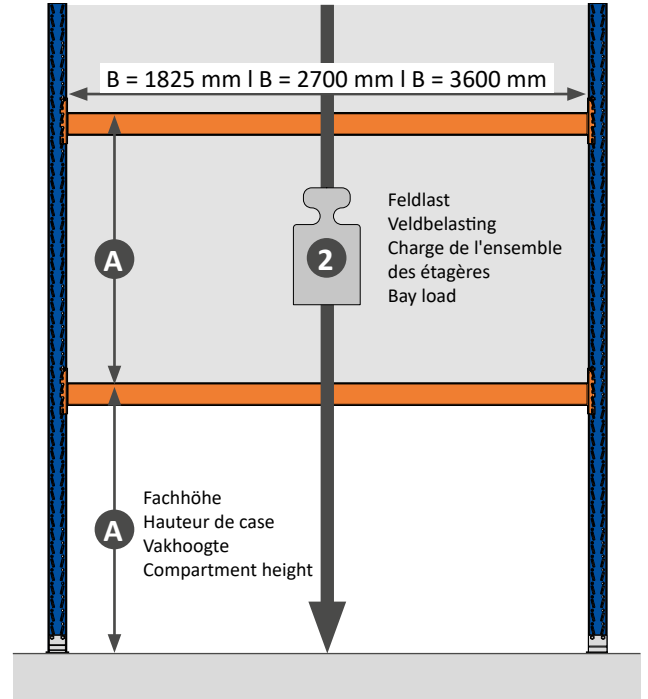
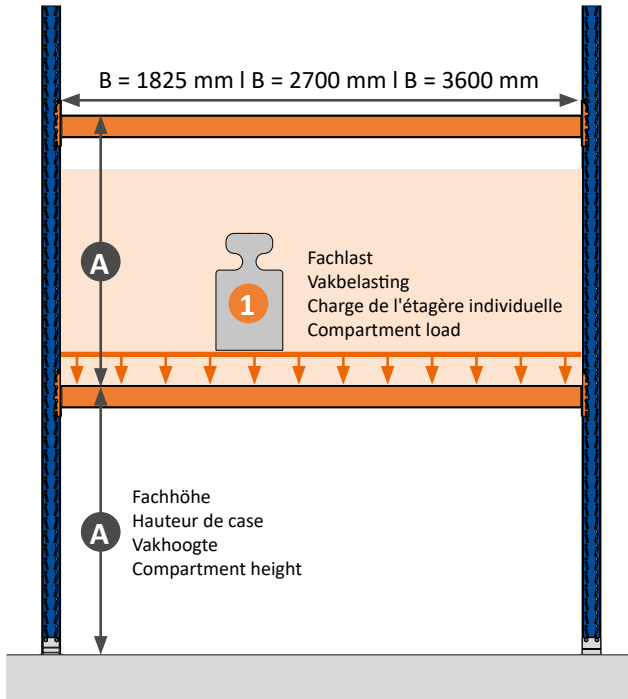

B = 1825 mm	≤ 3000 kg
B = 2700 mm	≤ 3000 kg
B = 3600 mm	≤ 3700 kg

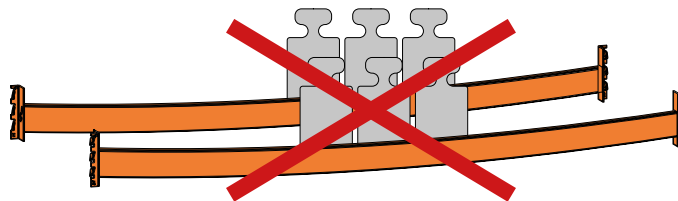

D Belastungsangaben

F Indications de charge | NL Laadgegevens | GB Load data



B = 1825 mm (RTP-080)



	2 x		3 x		4 x		5 x		6 x	
	1	2	1	2	1	2	1	2	1	2
T = 1100 mm (H20)										
770 mm	3000 kg	6000 kg	3000 kg	9000 kg	3000 kg	12000 kg	2700 kg	13500 kg	2200 kg	13200 kg
910 mm	3000 kg	6000 kg	3000 kg	9000 kg	3000 kg	12000 kg	2700 kg	13500 kg	2200 kg	13200 kg
1120 mm	3000 kg	6000 kg	3000 kg	9000 kg	2900 kg	11600 kg	2500 kg	12500 kg	-	-
1330 mm	3000 kg	6000 kg	3000 kg	9000 kg	2700 kg	10800 kg	2300 kg	11500 kg	-	-
1540 mm	3000 kg	6000 kg	2900 kg	8700 kg	2500 kg	10000 kg	-	-	-	-
1890 mm	3000 kg	6000 kg	2700 kg	8100 kg	-	-	-	-	-	-
2310 mm	2900 kg	5800 kg	-	-	-	-	-	-	-	-
T = 900 mm (H20)										
770 mm	3000 kg	6000 kg	3000 kg	9000 kg	3000 kg	12000 kg	2700 kg	13500 kg	2200 kg	13200 kg
910 mm	3000 kg	6000 kg	3000 kg	9000 kg	3000 kg	12000 kg	2700 kg	13500 kg	2200 kg	13200 kg
1120 mm	3000 kg	6000 kg	3000 kg	9000 kg	2900 kg	11600 kg	2500 kg	12500 kg	-	-
1330 mm	3000 kg	6000 kg	3000 kg	9000 kg	2700 kg	10800 kg	2300 kg	11500 kg	-	-
1540 mm	3000 kg	6000 kg	2900 kg	8700 kg	2500 kg	10000 kg	-	-	-	-
1890 mm	3000 kg	6000 kg	2700 kg	8100 kg	-	-	-	-	-	-
2310 mm	2900 kg	5800 kg	-	-	-	-	-	-	-	-
T = 750 mm (H20)										
770 mm	3000 kg	6000 kg	3000 kg	9000 kg	3000 kg	12000 kg	2700 kg	13500 kg	2200 kg	13200 kg
910 mm	3000 kg	6000 kg	3000 kg	9000 kg	3000 kg	12000 kg	2700 kg	13500 kg	2200 kg	13200 kg
1120 mm	3000 kg	6000 kg	3000 kg	9000 kg	2900 kg	11600 kg	2500 kg	12500 kg	-	-
1330 mm	3000 kg	6000 kg	3000 kg	9000 kg	2700 kg	10800 kg	2300 kg	11500 kg	-	-
1540 mm	3000 kg	6000 kg	2900 kg	8700 kg	2500 kg	10000 kg	-	-	-	-
1890 mm	3000 kg	6000 kg	2700 kg	8100 kg	-	-	-	-	-	-
2310 mm	2900 kg	5800 kg	-	-	-	-	-	-	-	-



Fachlast
Vakbelasting
Charge de l'étagère individuelle
Compartment load



Feldlast
Veldbelasting
Charge de l'ensemble des étagères
Bay load

(D) Belastungsangaben

(F) Indications de charge

(NL) Laadgegevens

(GB) Load data



B = 2700 mm (RTP-110)



	2 x		3 x		4 x		5 x		6 x	
	1	2	1	2	1	2	1	2	1	2
T = 1100 mm (H20)										
770 mm	3000 kg	6000 kg	3000 kg	9000 kg	3000 kg	12000 kg	2700 kg	13500 kg	2200 kg	13200 kg
910 mm	3000 kg	6000 kg	3000 kg	9000 kg	3000 kg	12000 kg	2700 kg	13500 kg	2200 kg	13200 kg
1120 mm	3000 kg	6000 kg	3000 kg	9000 kg	3000 kg	12000 kg	2600 kg	13000 kg	-	-
1330 mm	3000 kg	6000 kg	3000 kg	9000 kg	2900 kg	11600 kg	2400 kg	12000 kg	-	-
1540 mm	3000 kg	6000 kg	3000 kg	9000 kg	2700 kg	10800 kg	-	-	-	-
1890 mm	3000 kg	6000 kg	3000 kg	9000 kg	-	-	-	-	-	-
2310 mm	3000 kg	6000 kg	-	-	-	-	-	-	-	-
T = 900 mm (H20)										
770 mm	3000 kg	6000 kg	3000 kg	9000 kg	3000 kg	12000 kg	2700 kg	13500 kg	2200 kg	13200 kg
910 mm	3000 kg	6000 kg	3000 kg	9000 kg	3000 kg	12000 kg	2700 kg	13500 kg	2200 kg	13200 kg
1120 mm	3000 kg	6000 kg	3000 kg	9000 kg	3000 kg	12000 kg	2600 kg	13000 kg	-	-
1330 mm	3000 kg	6000 kg	3000 kg	9000 kg	2900 kg	11600 kg	2400 kg	12000 kg	-	-
1540 mm	3000 kg	6000 kg	3000 kg	9000 kg	2700 kg	10800 kg	-	-	-	-
1890 mm	3000 kg	6000 kg	3000 kg	9000 kg	-	-	-	-	-	-
2310 mm	3000 kg	6000 kg	-	-	-	-	-	-	-	-
T = 750 mm (H20)										
770 mm	3000 kg	6000 kg	3000 kg	9000 kg	3000 kg	12000 kg	2700 kg	13500 kg	2200 kg	13200 kg
910 mm	3000 kg	6000 kg	3000 kg	9000 kg	3000 kg	12000 kg	2700 kg	13500 kg	2200 kg	13200 kg
1120 mm	3000 kg	6000 kg	3000 kg	9000 kg	3000 kg	12000 kg	2600 kg	13000 kg	-	-
1330 mm	3000 kg	6000 kg	3000 kg	9000 kg	2900 kg	11600 kg	2400 kg	12000 kg	-	-
1540 mm	3000 kg	6000 kg	3000 kg	9000 kg	2700 kg	10800 kg	-	-	-	-
1890 mm	3000 kg	6000 kg	3000 kg	9000 kg	-	-	-	-	-	-
2310 mm	3000 kg	6000 kg	-	-	-	-	-	-	-	-



Fachlast
Vakbelasting
Charge de l'étagère individuelle
Compartment load



Feldlast
Veldbelasting
Charge de l'ensemble des étagères
Bay load

D Belastungsangaben

F Indications de charge | NL Laadgegevens | GB Load data



B = 3600 mm (RTP-160)



A	2 x		3 x		4 x		5 x		6 x	
	1	2	1	2	1	2	1	2	1	2
T = 1100 mm (H20)										
770 mm	3400 kg	6800 kg	3400 kg	10200 kg	3200 kg	12800 kg	2700 kg	13500 kg	2300 kg	13800 kg
910 mm	3400 kg	6800 kg	3400 kg	10200 kg	3200 kg	12800 kg	2700 kg	13500 kg	2300 kg	13800 kg
1120 mm	3400 kg	6800 kg	3300 kg	9900 kg	3200 kg	12800 kg	2600 kg	13000 kg	-	-
1330 mm	3400 kg	6800 kg	3300 kg	9900 kg	3000 kg	12000 kg	2500 kg	12500 kg	-	-
1540 mm	3400 kg	6800 kg	3200 kg	9600 kg	2900 kg	11600 kg	-	-	-	-
1890 mm	3300 kg	6600 kg	3000 kg	9000 kg	-	-	-	-	-	-
2310 mm	3200 kg	6400 kg	-	-	-	-	-	-	-	-
T = 900 mm (H20)										
770 mm	3400 kg	6800 kg	3400 kg	10200 kg	3200 kg	12800 kg	2700 kg	13500 kg	2200 kg	13200 kg
910 mm	3400 kg	6800 kg	3400 kg	10200 kg	3200 kg	12800 kg	2700 kg	13500 kg	2200 kg	13200 kg
1120 mm	3400 kg	6800 kg	3300 kg	9900 kg	3200 kg	12800 kg	2600 kg	13000 kg	-	-
1330 mm	3400 kg	6800 kg	3300 kg	9900 kg	3000 kg	12000 kg	2500 kg	12500 kg	-	-
1540 mm	3400 kg	6800 kg	3200 kg	9600 kg	2900 kg	11600 kg	-	-	-	-
1890 mm	3300 kg	6600 kg	3000 kg	9000 kg	-	-	-	-	-	-
2310 mm	3200 kg	6400 kg	-	-	-	-	-	-	-	-
T = 750 mm (H20)										
770 mm	3400 kg	6800 kg	3400 kg	10200 kg	3200 kg	12800 kg	2700 kg	13500 kg	2200 kg	13200 kg
910 mm	3400 kg	6800 kg	3400 kg	10200 kg	3200 kg	12800 kg	2700 kg	13500 kg	2200 kg	13200 kg
1120 mm	3400 kg	6800 kg	3300 kg	9900 kg	3200 kg	12800 kg	2600 kg	13000 kg	-	-
1330 mm	3400 kg	6800 kg	3300 kg	9900 kg	3000 kg	12000 kg	2500 kg	12500 kg	-	-
1540 mm	3400 kg	6800 kg	3200 kg	9600 kg	2900 kg	11600 kg	-	-	-	-
1890 mm	3300 kg	6600 kg	3000 kg	9000 kg	-	-	-	-	-	-
2310 mm	3200 kg	6400 kg	-	-	-	-	-	-	-	-



Fachlast
Vakbelasting
Charge de l'étagère individuelle
Compartment load



Feldlast
Veldbelasting
Charge de l'ensemble des étagères
Bay load

D Belastungsangaben

F Indications de charge | NL Laadgegevens | GB Load data

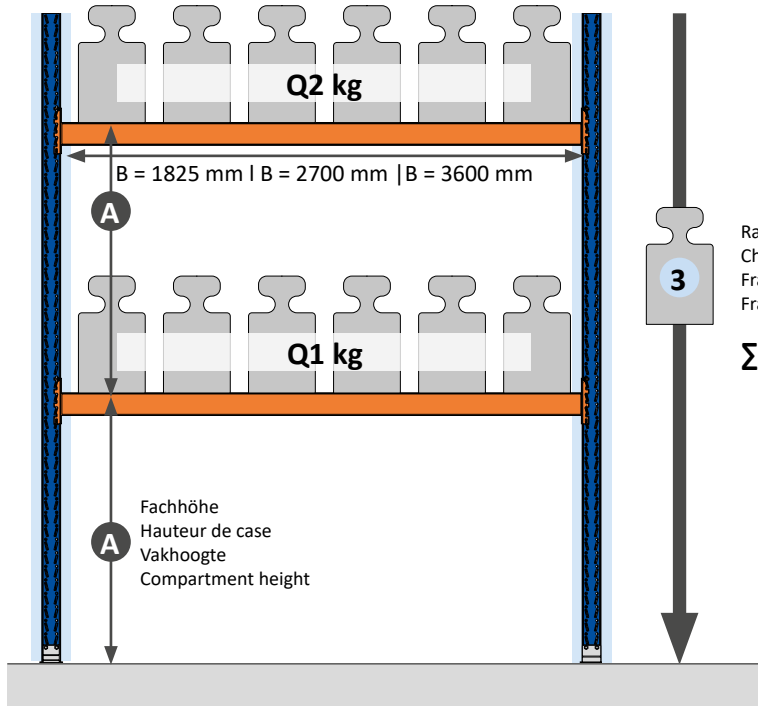

Rahmenlast
Charge de cadre
Frame belasting
Frame load

$$\Sigma \text{ kg} = Q1 \text{ kg} + Q2 \text{ kg} + \dots + Q6 \text{ kg}$$



Max Σ kg			
← B = 1825 mm B = 2700 mm B = 3600 mm →			
x 80 %	x 85 %	x 90 %	x 100 %

Beispiel:
Exempel:
Voorbeeld:
Example:



T = 1100 mm
A = 1540 mm
B = 1825 mm
2 x B

$$\text{Max } \Sigma \text{ kg} = 8800 \text{ kg} \times 85 \% = 7480 \text{ kg}$$

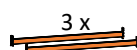







(D) Belastungsangaben

(F) Indications de charge | **(NL)** Laadgegevens | **(GB)** Load data

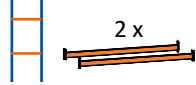
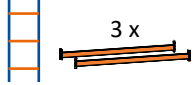
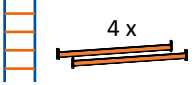
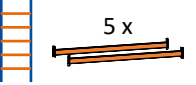
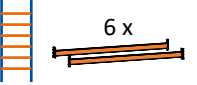

B = 1825 mm (RTP-080)



	 2 x	 3 x	 4 x	 5 x	 6 x
					
T = 1100 mm (H20)					
770 mm	6700 kg	9900 kg	13100 kg	14400 kg	14700 kg
910 mm	6600 kg	9800 kg	12600 kg	13700 kg	13900 kg
1120 mm	6600 kg	9500 kg	11800 kg	12700 kg	-
1330 mm	6500 kg	9200 kg	11100 kg	11800 kg	-
1540 mm	6400 kg	8800 kg	10300 kg	-	-
1890 mm	6100 kg	8100 kg	-	-	-
2310 mm	5800 kg	-	-	-	-
T = 900 mm (H20)					
770 mm	6700 kg	9900 kg	13100 kg	14400 kg	14700 kg
910 mm	6700 kg	9800 kg	12600 kg	13700 kg	13900 kg
1120 mm	6600 kg	9500 kg	11800 kg	12700 kg	-
1330 mm	6500 kg	9200 kg	11100 kg	11800 kg	-
1540 mm	6400 kg	8800 kg	10300 kg	-	-
1890 mm	6100 kg	8100 kg	-	-	-
2310 mm	5800 kg	-	-	-	-
T = 750 mm (H20)					
770 mm	6700 kg	9900 kg	13100 kg	14400 kg	14700 kg
910 mm	6700 kg	9800 kg	12600 kg	13700 kg	13900 kg
1120 mm	6600 kg	9500 kg	11800 kg	12700 kg	-
1330 mm	6500 kg	9200 kg	11100 kg	11800 kg	-
1540 mm	6400 kg	8800 kg	10300 kg	-	-
1890 mm	6100 kg	8100 kg	-	-	-
2310 mm	5800 kg	-	-	-	-

 =
 Rahmenlast
 Charge de cadre
 Frame belasting
 Frame load

(D) Belastungsangaben

(F) Indications de charge

(NL) Laadgegevens

(GB) Load data



B = 2700 mm (RTP-110)

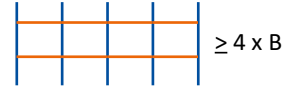
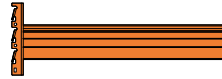

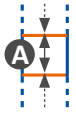
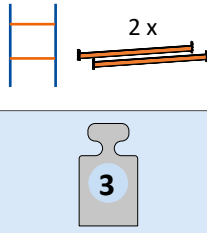
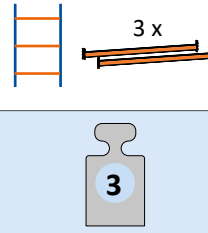
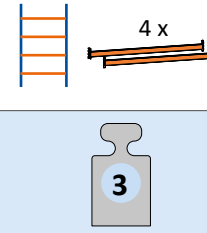
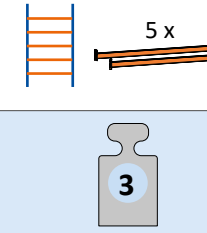
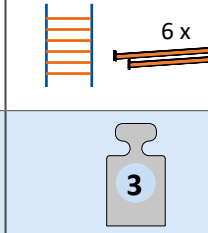
	2 x	3 x	4 x	5 x	6 x
					
T = 1100 mm (H20)					
770 mm	6600 kg	9900 kg	14100 kg	14400 kg	14300 kg
910 mm	6600 kg	9900 kg	13500 kg	13900 kg	13700 kg
1120 mm	6600 kg	9900 kg	12600 kg	13000 kg	-
1330 mm	6600 kg	9800 kg	11800 kg	12200 kg	-
1540 mm	6600 kg	9600 kg	11000 kg	-	-
1890 mm	6500 kg	9000 kg	-	-	-
2310 mm	6300 kg	-	-	-	-
T = 900 mm (H20)					
770 mm	6600 kg	9900 kg	14100 kg	14400 kg	14300 kg
910 mm	6600 kg	9900 kg	13500 kg	13800 kg	13800 kg
1120 mm	6600 kg	9900 kg	12600 kg	13000 kg	-
1330 mm	6600 kg	9800 kg	11800 kg	12200 kg	-
1540 mm	6600 kg	9600 kg	11000 kg	-	-
1890 mm	6500 kg	9000 kg	-	-	-
2310 mm	6300 kg	-	-	-	-
T = 750 mm (H20)					
770 mm	6600 kg	9900 kg	14100 kg	14400 kg	14300 kg
910 mm	6600 kg	9900 kg	13500 kg	13800 kg	13800 kg
1120 mm	6600 kg	9900 kg	12600 kg	13000 kg	-
1330 mm	6600 kg	9800 kg	11800 kg	12200 kg	-
1540 mm	6600 kg	9600 kg	11000 kg	-	-
1890 mm	6500 kg	9000 kg	-	-	-
2310 mm	6300 kg	-	-	-	-



Rahmenlast
Charge de cadre
Frame belasting
Frame load

D Belastungsangaben

F Indications de charge | NL Laadgegevens | GB Load data



B = 3600 mm (RTP-160)



	2 x	3 x	4 x	5 x	6 x
T = 1100 mm (H20)					
770 mm	6900 kg	10400 kg	13600 kg	14100 kg	14500 kg
910 mm	6900 kg	10300 kg	13200 kg	13700 kg	14000 kg
1120 mm	6900 kg	10100 kg	12700 kg	13100 kg	-
1330 mm	6800 kg	9800 kg	12200 kg	12500 kg	-
1540 mm	6700 kg	9600 kg	11600 kg	-	-
1890 mm	6600 kg	9100 kg	-	-	-
2310 mm	6300 kg	-	-	-	-
T = 900 mm (H20)					
770 mm	6900 kg	10400 kg	13600 kg	14100 kg	14400 kg
910 mm	6900 kg	10300 kg	13200 kg	13700 kg	13900 kg
1120 mm	6900 kg	10100 kg	12700 kg	13100 kg	-
1330 mm	6800 kg	9800 kg	12200 kg	12400 kg	-
1540 mm	6700 kg	9600 kg	11600 kg	-	-
1890 mm	6600 kg	9100 kg	-	-	-
2310 mm	6300 kg	-	-	-	-
T = 750 mm (H20)					
770 mm	6900 kg	10400 kg	13600 kg	14100 kg	14300 kg
910 mm	6900 kg	10300 kg	13200 kg	13700 kg	13800 kg
1120 mm	6900 kg	10100 kg	12700 kg	13000 kg	-
1330 mm	6800 kg	9800 kg	12200 kg	12400 kg	-
1540 mm	6700 kg	9600 kg	11600 kg	-	-
1890 mm	6600 kg	9100 kg	-	-	-
2310 mm	6300 kg	-	-	-	-

= Rahmenlast
Charge de cadre
Frame belasting
Frame load

D Toleranzen

F Tolérances | NL Toleranties | GB Tolerances

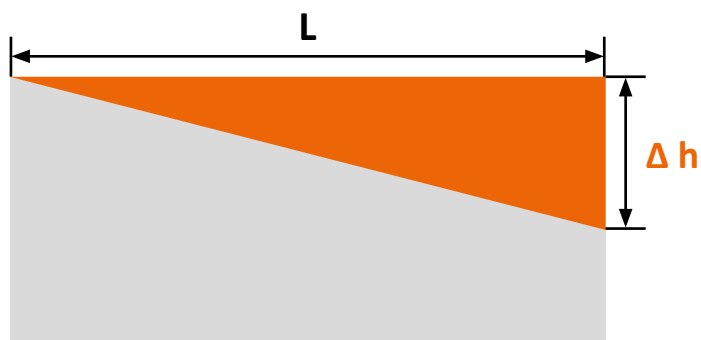
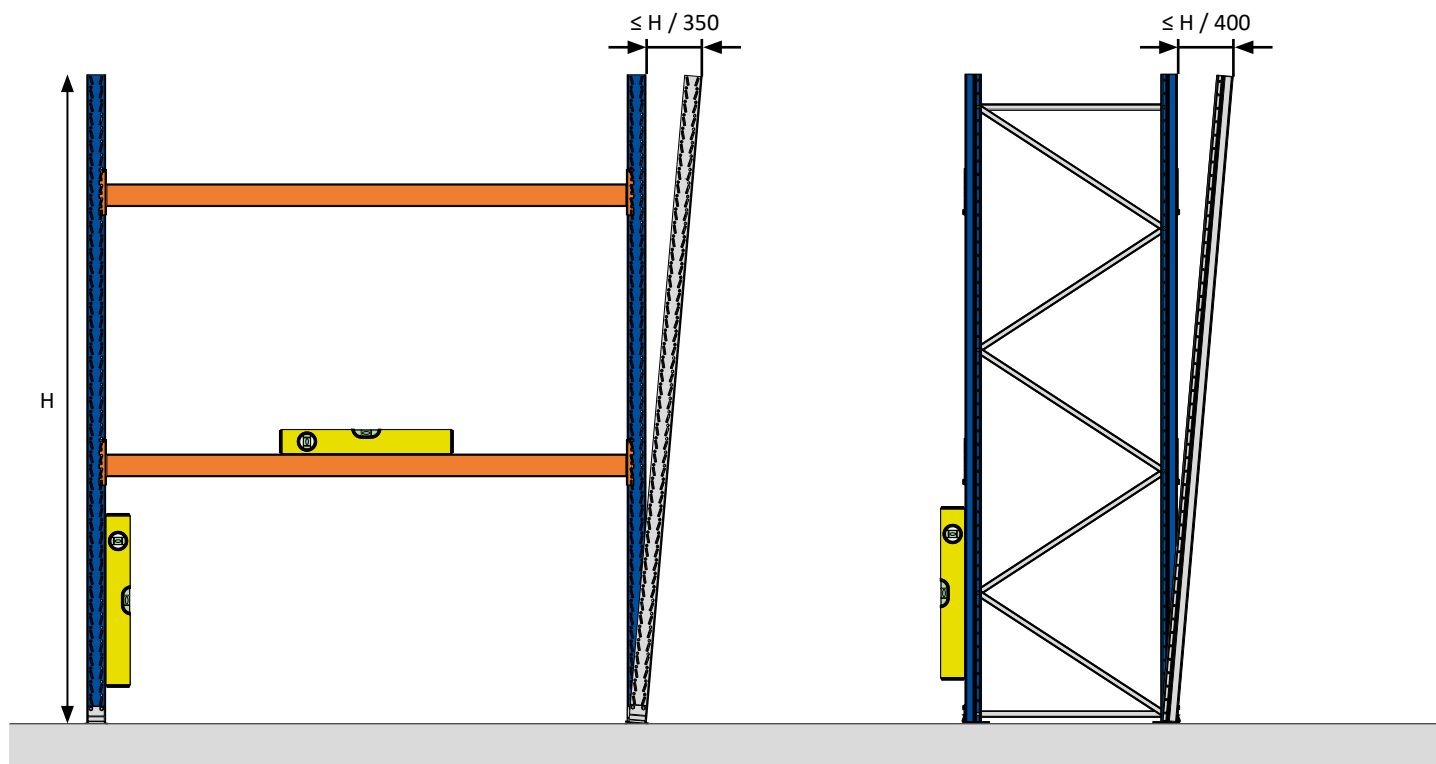

$\longleftrightarrow L \longleftrightarrow$	Δh
$\leq 1 \text{ m}$	$\leq 4 \text{ mm}$
$\leq 4 \text{ m}$	$\leq 10 \text{ mm}$
$\leq 10 \text{ m}$	$\leq 12 \text{ mm}$
$\leq 15 \text{ m}$	$\leq 15 \text{ mm}$