



100 l

200 l

400 l

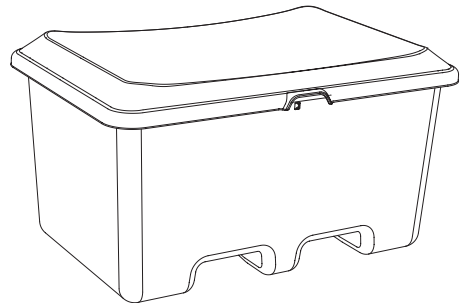
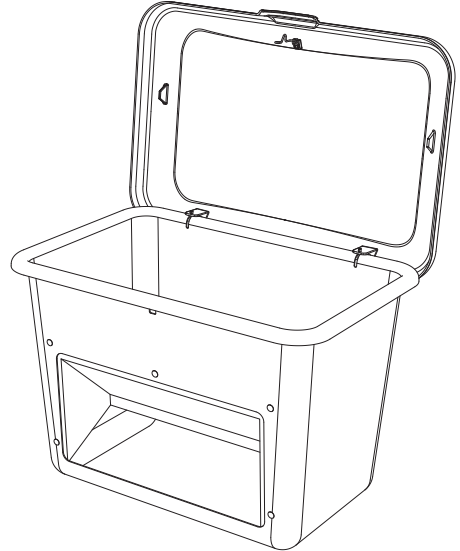

- D** Streugutbox
- GB** Grit Box
- F** Bac à sel
- I** Box per materiale da spargere
- E** Depósito para gravilla antideslizante
- CZ** Box na posypový materiál
- DK** Gruskasse
- EST** Puisteaine boks
- H** Szórándó anyag tároló
- N** Strømaterialboksen
- NL** Strooigoedbox
- P** Recipiente para material de dispersão
- PL** Skrzynia na materiał do sypania
- RO** Curie pentru materialul de împrăștiat
- RUS** Ящик разбрасываемого материала
- S** Sandlåda
- SK** Box na posypový materiál
- SF** Hiekoiituslaatikko
- SLO** Zabojnîk za material za posipanje
- TR** Serpme maddeleri depolama kutusu

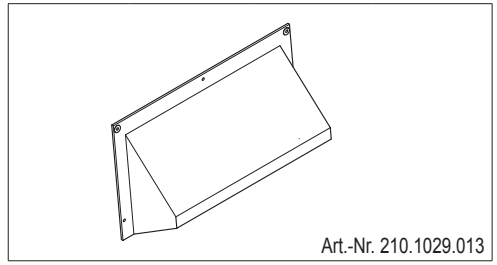

- D** Montage Nachrutscheinsatz
- GB** Installation of the deflector insert
- F** Montage du dispositif d'écoulement
- I** Montaggio inserto avanzamento
- E** Montaje del accesorio antideslizante
- CZ** Montáž vložky skluzu
- DK** Montering af indsatsen til spredning i takt
- EST** Pealevoolusisendi paigaldamine
- H** Az utáncsúszó betét felszerelése
- N** Montering etterinnføringsinnsats
- NL** Montage naglijdinzetstuk
- P** Montagem do encaixe de deslize
- PL** Montaż wkładu zsuwowego
- RO** Montare insertie de avans
- RUS** Установка скользящей вставки
- S** Montering av rinninsats
- SK** Montáž vložky sklzu
- SF** Liukukappaleen asennus
- SLO** Montaža vstavka za dotekanje
- TR** Montaj Sarma tertibatı

	200 l	400 l
--	--------------	--------------



5 x		M 6 x 20 CEMO-A2	Art.-Nr. 900.9906.020.A2
5 x		A 6,4 DIN EN ISO 7093-1-A2	Art.-Nr.900.4606.000.A2
5 x		M 6 DIN EN 24032-A2	Art.-Nr. 900.1706.000.A2

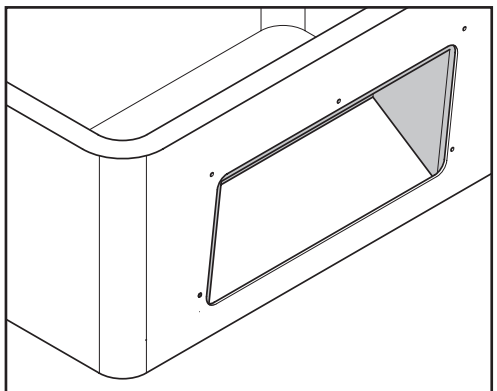
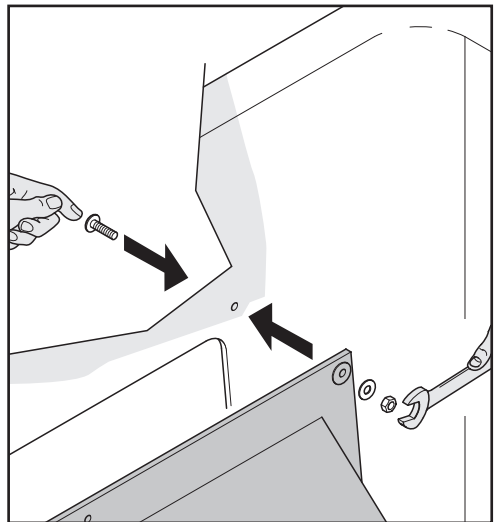



- D** Montage Fanghaken
- GB** Installation of the catch hook
- F** Montage du crochet de fermeture
- I** Montaggio gancio di presa
- E** Montaje del gancho de sujeción
- CZ** Montáž záchytných háků
- DK** Montering fangekrok
- EST** Kinnituskonksu paigaldamine
- H** A fogóhorog felszerelése
- N** Montering fangekrok
- NL** Montage vanghaak
- P** Montagem do gancho de retenção
- PL** Montaż haka chwytającego
- RO** Montare cârlig de prindere
- RUS** Установка крюка
- S** Montering av fånghake
- SK** Montáž záchytných hákov
- SF** Tarttumakoukun asennus
- SLO** Montaža lovilnega kavljca
- TR** Montaj Tutma kancası

100 I

200 I

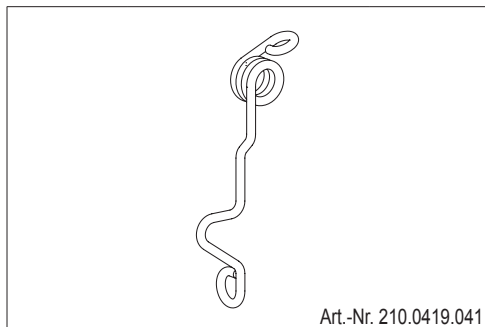
400 I



1 x	 M 6 x 15 CEMO-A2	Art.-Nr. 900.9906.015.A2
1 x	 M 6 DIN EN 24032-A2	Art.-Nr. 900.7606.000.A2

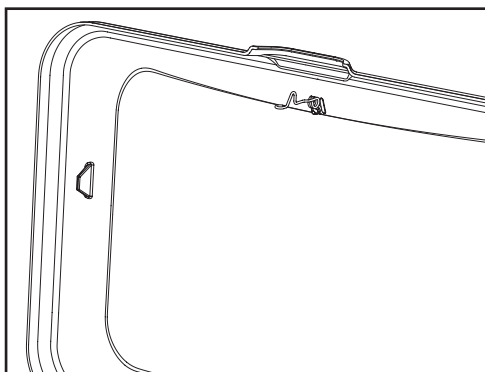
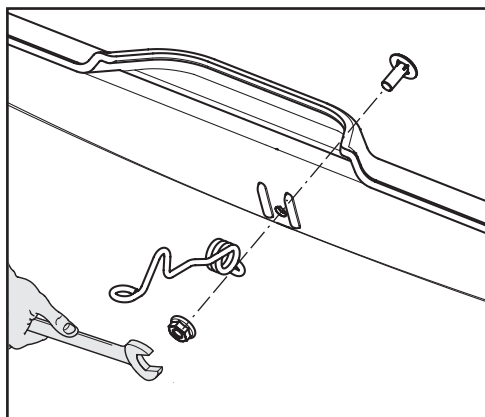

- D** Montage Deckel auf dem Behälter
- GB** Mounting lid on container
- F** Montage de couvercle sur le contenant
- I** Fissaggio del coperchio sul contenitore
- E** Montaje de la cubierta en el envase
- CZ** Montáž krytu na nádobě
- DK** Montering af låget på beholderen
- EST** Paigaldamine kaas mahutile
- H** Telepítse a fedelet a konténer
- N** Montering av dekselet på beholderen
- NL** Montage van de deksel op de container
- P** Instalação da tampa sobre o recipiente
- PL** Montaż pokrywy na pojemniku
- RO** Instalar a capacului pe recipient
- RUS** Крепления крышки к контейнеру
- S** Montering av locket till behållaren
- SK** Upevnite veko na nádobě
- SF** Kannen kiinnittäminen konttiin
- SLO** Pritrditev pokrova na posodo
- TR** Kap üzerinde kapağın montajı

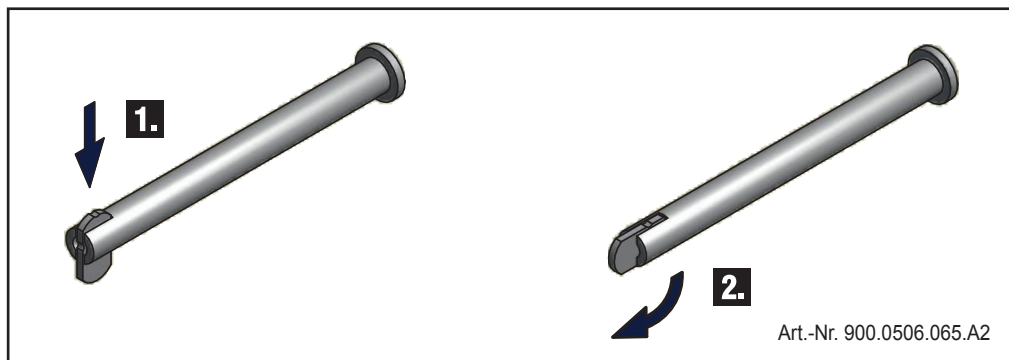
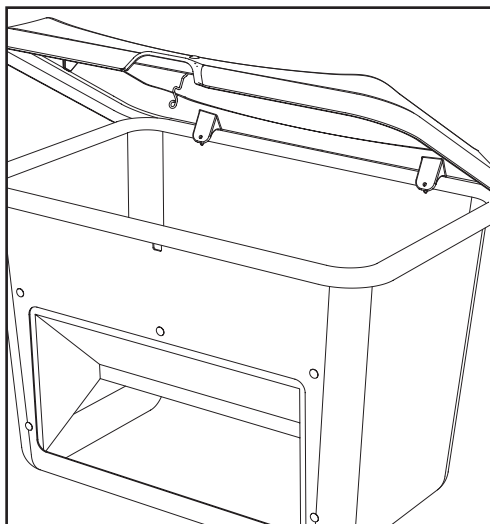
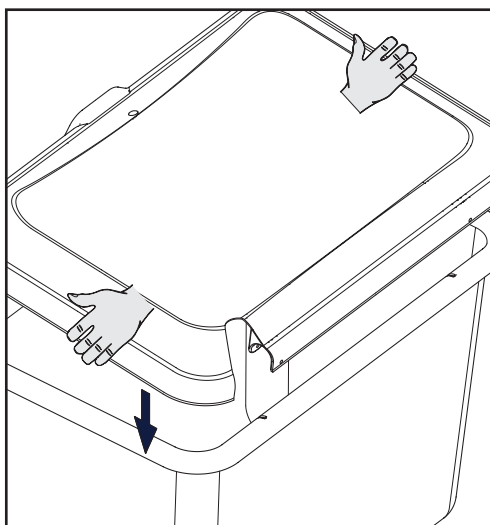

Art.-Nr. 900.0506.065.A2

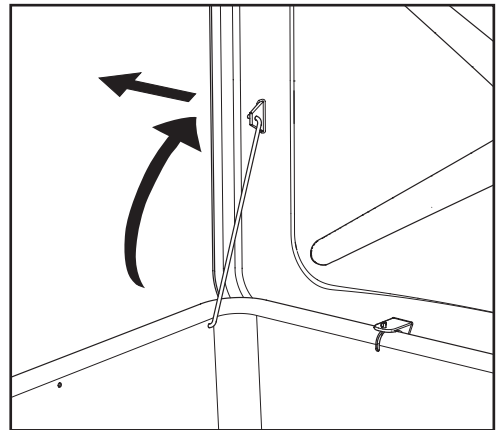
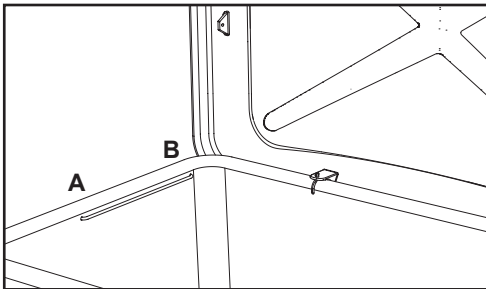
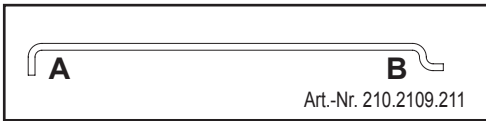
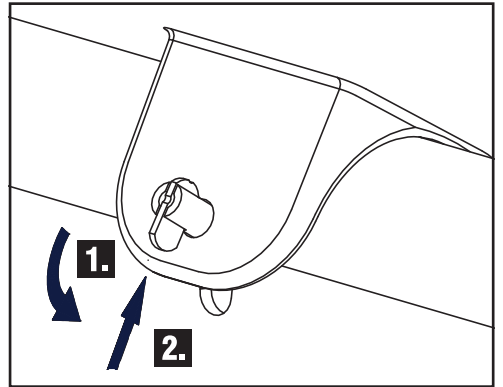
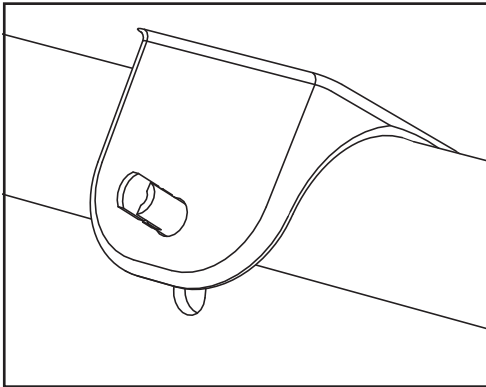
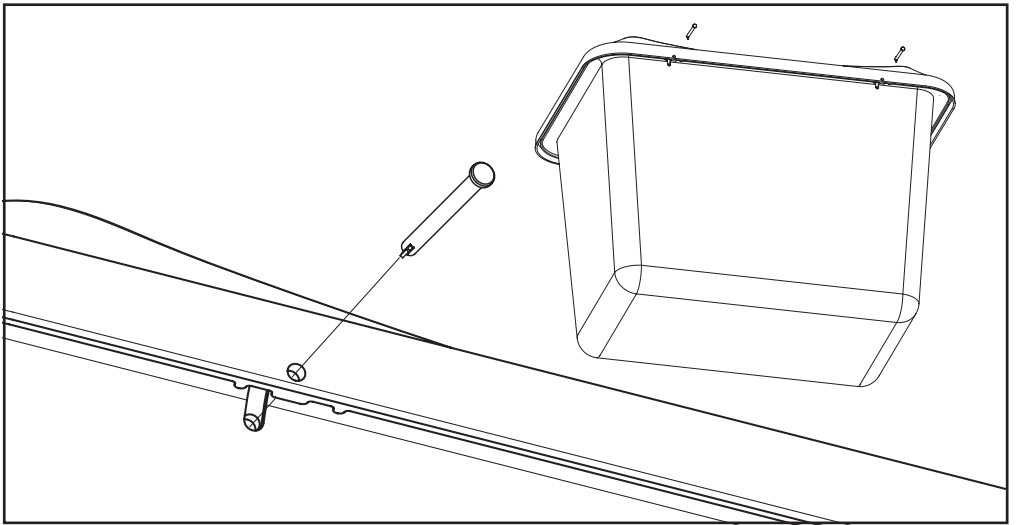

- D** Deckel aushängen
- GB** Unhinging the lid
- F** Déboîter le couvercle
- I** Sganciare il coperchio
- E** Desenganchar la tapa
- CZ** Viko vysadit
- DK** Hænge låget ud
- EST** Kaane väljariputamine
- H** A fedél kiakasztása
- N** Henge ut dekselet
- NL** Deksel uit de hengsels lichten
- P** Soltar a tampa
- PL** Odczepienie pokrywy
- RO** Montarea capacului
- RUS** Навешивание крышки
- S** Borttagning av locket
- SK** Veko vysadiť
- SF** Kannen poistaminen paikaltaan
- SLO** Odstranitev pokrova
- TR** Kapağı çıkartın

- D** Lagerung
- GB** Storage
- F** Stockage
- I** Stoccaggio
- E** Almacenaje
- CZ** Uložení
- DK** Lejring
- EST** Laagerdus
- H** Csapágyazás
- N** Lagring
- NL** Opslag
- P** Armazenamento
- PL** Przechowywanie
- RO** Depozitare
- RUS** Onopa
- S** Förvaring
- SK** Uloženie
- SF** Laakerointi
- SLO** Shranjevanje
- TR** Depolama

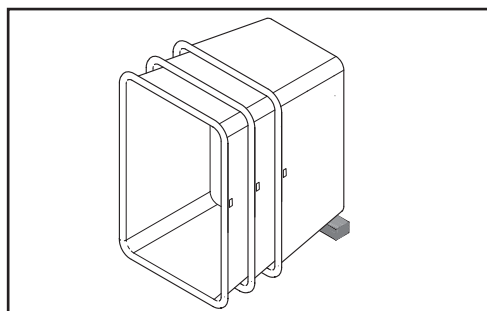
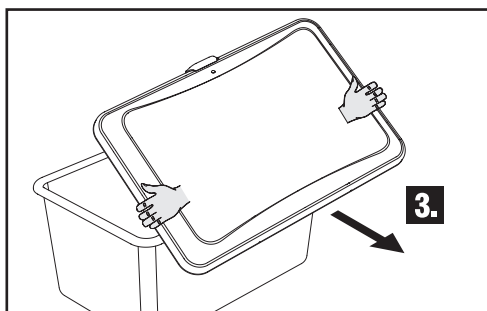
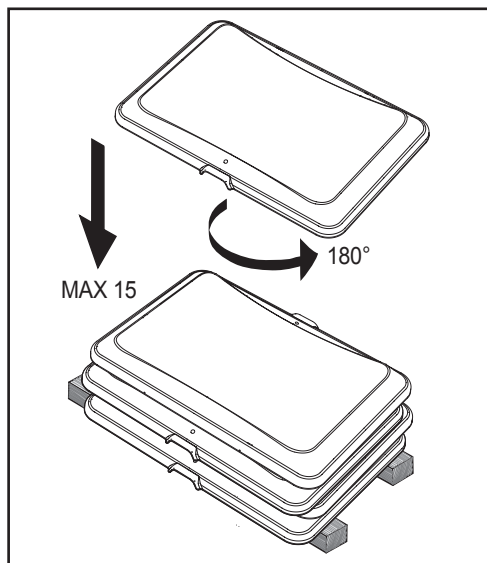
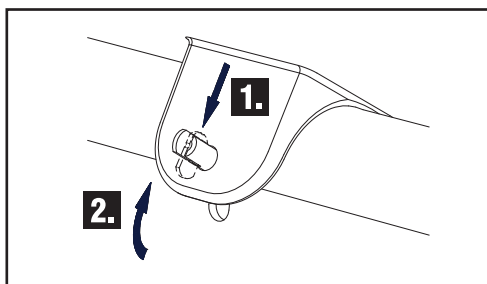

- D** Behälteraufstellung
- GB** Container setup
- F** Installation des bacs
- I** Installazione contenitori
- E** Colocación del depósito
- CZ** Postavení zásobníků
- DK** Opstilling af beholderen
- EST** Mahuti püstitamine
- H** A tartály felállítása
- N** Beholderopstilling
- NL** Containeropstelling
- P** Colocação do recipiente
- PL** Ustawienie skrzyni
- RO** Amplasarea rezervoarelor
- RUS** Установка емкости
- S** Uppställning av låda
- SK** Postavenie zásobníkov
- SF** Säiliön asennus käyttöpaikalle
- SLO** Postavitev zabojnikov
- TR** Deponun konumlandırılması

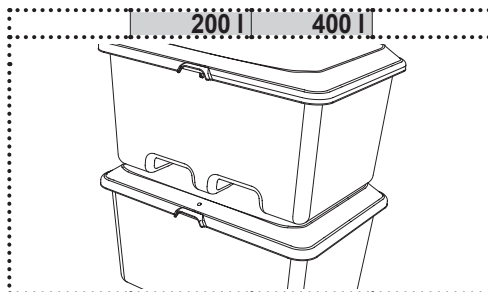
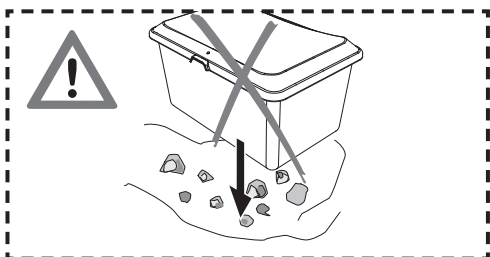
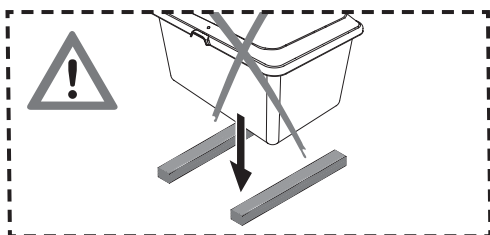
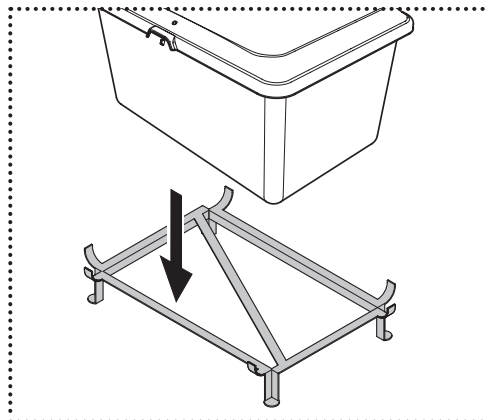
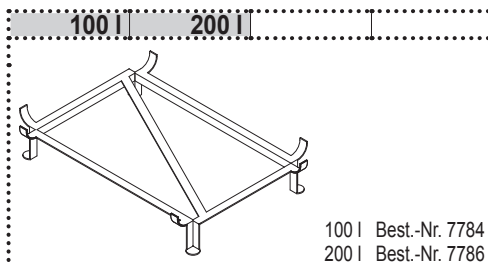
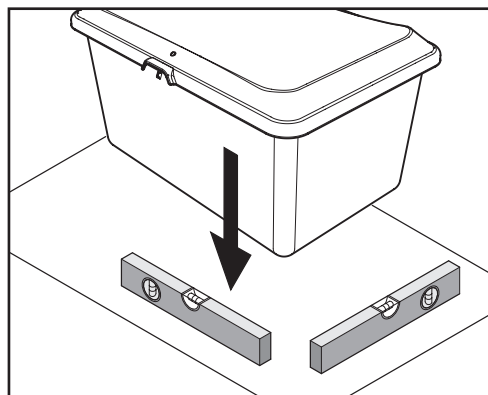

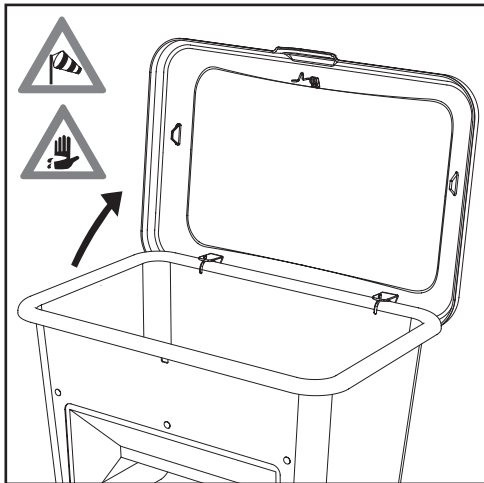
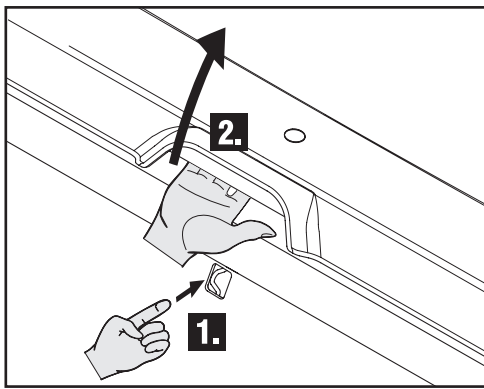

100 l | 200 l | 400 l



Best.-Nr. 1490

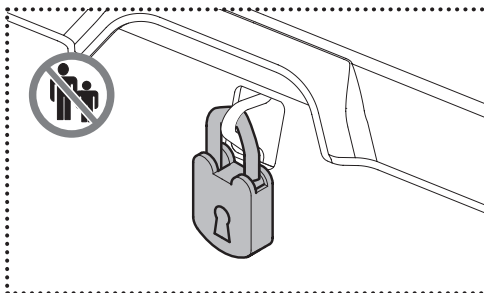

- D** Sicherheitsverschluss
- GB** Safety lock
- F** Fermeture de sécurité
- I** Chiusura di sicurezza
- E** Cierre de seguridad
- CZ** Bezpečnostní uzávěr
- DK** Sikkerhedslås
- EST** Turvalukk
- H** Biztonsági zár
- N** Sikkerhetslås
- NL** Veiligheidssluiting
- P** Fecho de segurança
- PL** Zamknięcie zabezpieczające
- RO** Încizător de siguranță
- RUS** Защитный запор
- S** Säkerhetslåsordning
- SK** Bezpečnostný uzáver
- SF** Turvalukitus
- SLO** Varnostna zapora
- TR** Güvenlik kapağı

